

**Maiman**

Superb Technology & Optimum Quality

# Stone series high power green laser

Instruction manual

VN: GSL20240606

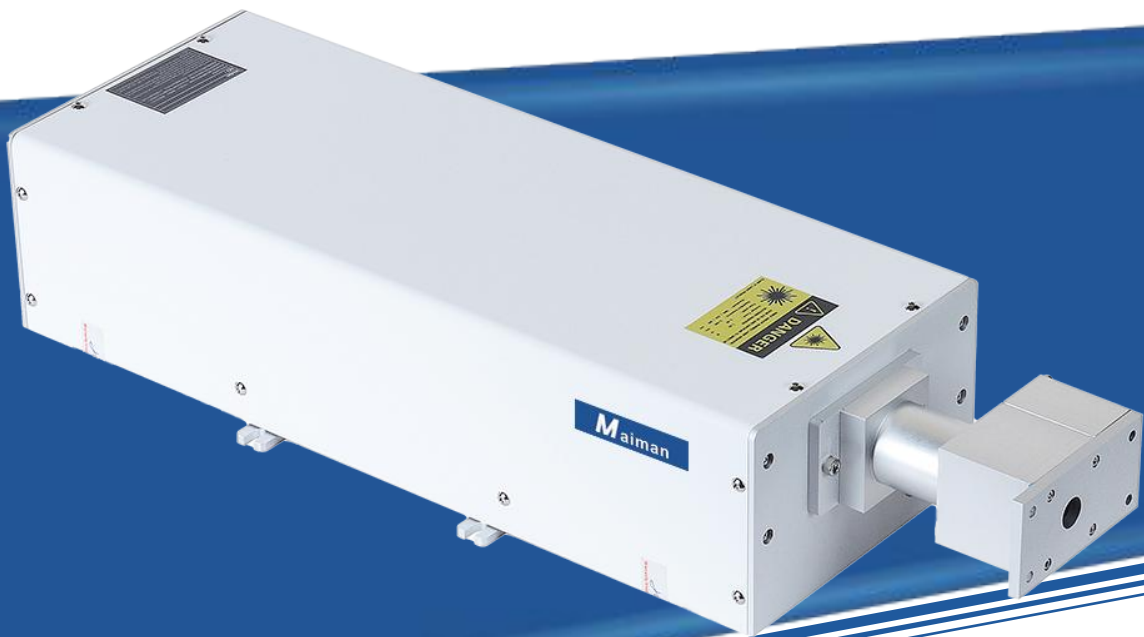

Tianjin Maiman Laser Technology Co., Ltd.

## Preface

This manual is applicable to engineers who have basic knowledge of hardware and have a certain understanding of laser equipment and device. Please read through this manual carefully before using the Maiman laser products and keep it properly. If you have any questions, please contact Tianjin Maiman Laser Technology Co., Ltd.

For more product and information, please visit our website  
[www.maimanlaser.com](http://www.maimanlaser.com)



# Content

1. Maiman Laser Safety Instructions	01
1.1 Declaration of Safe Use	01
1.2 Safety and Warning Signs	01
1.3 Guidelines for Safety Operation of the Laser	02
1.4 Product Safety Features	03
2. Product Installation Instructions	04
2.1 Laser Installation and Service Conditions	04
2.2 Supplied Accessories	05
2.3 Description of Laser Interface	06
2.4 Installation Instructions	08
2.4.1 Installation Method of Laser	08
2.5 Dimensional Drawing	09
3. Laser Operation Instructions	10
3.1 Startup Process	10
3.2 Shutdown Process	11
4. Connection with Common Systems and Software Settings	12
4.1 The Interface Diagram and Software Settings of EzCad Control Board	12
4.2 The Interface Diagram and Software Settings of Central-laser Control Board	14
4.3 The Interface Diagram and Software Settings of BSL Control Board	16
4.4 The Interface Diagram and Software Settings of Earain Control Board	17
5. Troubleshooting and Maintenance	18
5.1 What should I do if the laser does not emit laser	18
5.2 The laser intensity becomes weak after working for a period of time	18
6. After sale service	19
6.1 Warranty	19
6.2 Returns	19

# 1. Maiman Laser Safety Instructions

## 1.1 Declaration of Safe Use

The manual must be read through carefully before using the Maiman laser, and operators must operate in strict accordance with the guidelines of the manual, so as to avoid the damage to the human body and property caused by improper operation. If the operator does not use the product in accordance with the guidelines of the manual, Tianjin Maiman Laser Technology Co., Ltd. will not bear any legal responsibility for all personal and property damages arising therefrom.

## 1.2 Safety and Warning Signs/Labels

	<p>Laser radiation warning sign Viewing visible or invisible laser light emanating from the laser will cause serious injury and potential blindness, as is reflected, scattered, and diffuse light.</p>
	<p>Safety Warning sign The specific procedures need to be followed, otherwise your device or parts may be damaged or will bring danger. You need to follow specific procedures, otherwise your equipment or components may be damaged or dangerous.</p>
	<p>The production label</p>
	<p>Anti disassembly label I . No warranty if the label is damaged.</p>
	<p>Anti disassembly label II .No warranty if the label is damaged.</p>
	<p>Maiman's logo</p>
	<p>QR code</p>



### 1.3 Guidelines for Safety Operation of the Laser

- The laser products of our company belongs to class IV laser device ( $>500\text{mw}$ ) according to its output power level, The laser radiation will cause serious harm to human body, as well as fire and other hazards. Only qualified personnel who have been trained and are well aware of the danger of laser are allowed to operate this product. Non operators should evacuate outside the danger area of laser radiation.
- After long-distance transportation, the machine must be allowed to sit idle for half an hour before powering on. This waiting period is necessary to allow the laser to reach a stable ambient temperature and avoid power discrepancies caused by temperature variations within the cavity. Only after this waiting period should the power supply be switched on.
- Do not open the casing of the laser body under any circumstances.
- Establish a safe operation area around the laser and take necessary measures to prevent the leakage of the laser. Post Class IV laser warning signs and safety warning signs at obvious positions in the safe operation area to prevent untrained personnel from entering.
- Store the laser in a place with certain power protection conditions, and all parts of the laser should have good grounding protection.
- Wear professional laser protective glasses, gloves, protective clothing, etc. during operation. Do not look at the laser beam directly without protective measures, do not touch the laser beam directly to avoid damage to eyes, skin, clothing, etc.
- Do not wear jewelry or any reflective objects, and do not irradiate the light beam on the reflective surface, so as to avoid personal injury caused by the reflected light.
- Take measures to block the reflected beam, or use a working platform with CLASS IV protection grade when processing metal parts which may reflect beam strongly.
- Keep the laser beam above or below the human eyes during operation, do not keep it on the same level as the human eyes.
- If volatile substances are used in the laser operation area, cleaned them out of the operation area immediately after the operation.
- After operation, the operator should check with the fluorescent sheet to confirm that the laser has been turned off before leaving.
- The maintenance and repair of the device should be carried out by professionally trained personnel. Be sure to refer to the relevant contents in the manual.



## 1.4 Product Safety Features

- Power indicator light: Red - When the indicator lights up, it means the laser is powered on, but cannot judge whether the laser is on or off. Take great care at all times when using the laser. When the indicator light is off, it means that the laser is not powered on. At this time, the laser is in the off state.
- Work indicator light: Green - When the indicator lights up, it means that the laser can work normally, but cannot judge whether the laser is on or off. Take great care at all times when using the laser. When the indicator light is off, it means that the laser is not ready. At this time, the laser is in the off state.

## 2. Product Installation Instructions

### 2.1 Laser Installation and Service Conditions

- Do not power on the laser during installation and disassembly, otherwise the laser will be burned; at the same time, pay attention to anti-static to avoid electrostatic breakdown of the internal laser diode;
- The working temperature of the laser is  $25\text{ }^{\circ}\text{C} \pm 1\text{ }^{\circ}\text{C}$ , and too high or too low temperature will weaken the laser power;
- Replace the beam expander in a relatively clean environment without air flow to prevent dust from polluting the window mirror;  
**Remarks: beam expanders and window mirrors are not covered by warranty;**
- The laser power supply is a special switching power supply. Use the laser's own switching power supply. Do not replace it without permission. Connect the laser power supply cable correctly, otherwise the laser will be burned directly;
- Pay attention to the cleanliness of the chiller. Pollution is likely to block the internal waterway of the laser and affect the normal working of the laser. Please use antifreeze below  $0\text{ }^{\circ}\text{C}$  to prevent freezing. The freezing of cold water will deform the laser and cause power attenuation;
- Laser damage caused by human factors is not within the scope of warranty;
- No warranty if the anti disassembly label is damaged.

Category	Item	Specification
Electrical requirements	Switching power supply input voltage	AC100-240V, 50-60Hz
	Switching power supply output voltage/current	DC12V , 29A or DC15V, 23A
	Laser input voltage/current	DC12V , 29A or DC15V, 23A
	Running power	350W
Environmental requirements	Storage temperature	-10-40°C
	Storage humidity	<90%( No condensation)
	Operating temperature	10-35°C
	Operating humidity	<80%( No condensation)
	Dust	< 0.20mg/m <sup>3</sup>
	Oil mist	Non
	Electromagnetic environment	GB Glass II
Chiller requirements	Shock	Isolate vibration sources
	Cooling power	1.5kW
	Set temperature	25°C
	Refrigeration temperature fluctuation	$\pm 0.1\text{ }^{\circ}\text{C}$
	Water flow	10L/min@0.18MPa
	Pump head	20m

Remark: •The coolant of the chiller should be pure water, distilled water or deionized water. Do not use daily drinking water or mineral water. Otherwise, the water channel will be easily blocked and the laser will be damaged.

## 2.2 Supplied Accessories

NO.	Item	Picture	Qty	Unit	Description
1	Stone series high power green laser		1	set	10W/15W/20W
2	Galvanometer adapter plate		1	piece	9.6cm*4.7cm
4	Switching power supply		1	piece	LRS-350-12 / LRS-350-15
5	Power supply cable		1	piece	3*2.5, 2m
6	Fixed foot		3-4	piece	M4
7	9-pin plug		1	set	DB9 pin
8	9-pin housing		1	set	DB9 pin shell
9	Galvanometer adapter plate screws		4	↑	M5*12
10	Screw of fixing feet		6-8	↑	M4*10

Remark: ●The photos are for reference only, and the real object shall prevail.



### 2.3 Description of Laser Interface

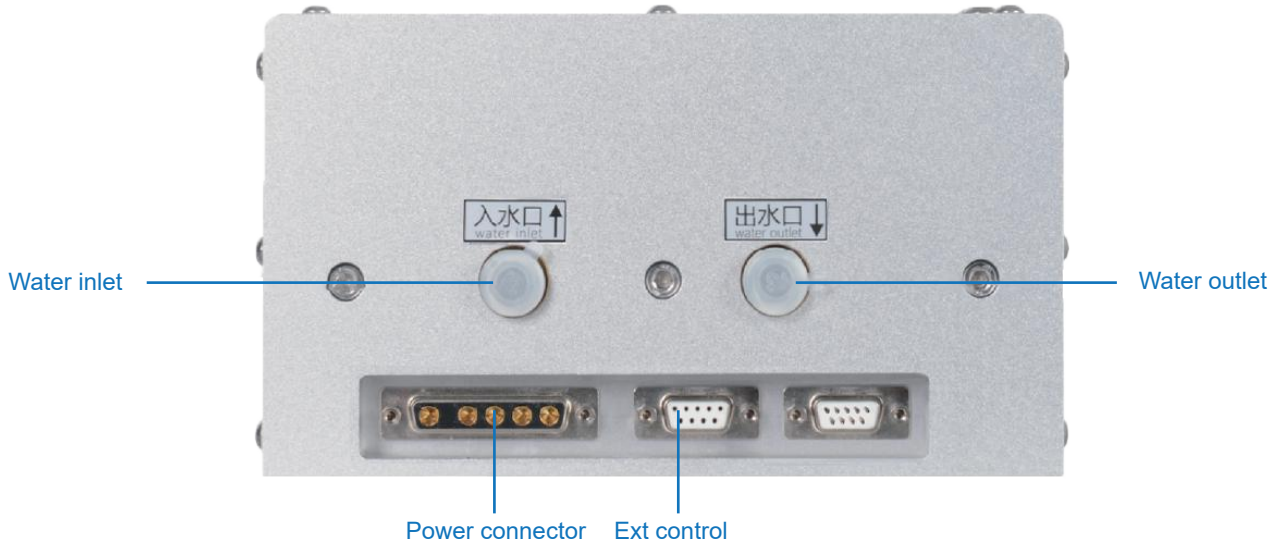

- **Power connector**

Provides DC constant voltage power supply for the laser. The laser is powered by the attached power supply cable and AC-DC switching power supply. Pay attention not to short circuit or connect incorrectly during wiring, otherwise the laser will be burned directly;

- **Cooling water interface (water inlet and water outlet)**

Provide cooling for the laser. Use a pneumatic tube or a hard water tube with an outer diameter of 10mm to connect the "water outlet" of the chiller to the "water inlet" of the laser, and the "water inlet" of the chiller to the "water outlet" of the laser. Connect the joint tightly to ensure no water leakage. When replacing the water tube, first press the edge of the water tube joint to make the joint completely flat, and then pull out the water tube. Do not pull it out directly, which will cause water leakage of the joint.

- **Ext control**

Control laser output and parameter adjustment. It is the external control interface (pin DB9), which is connected with the control board and the water pressure protection signal of the chiller, as defined below:

No.	Item	Description
Pin 1	Water pressure protection line of chiller	
Pin 2	Water pressure protection line of chiller	
Pin 3	NC (vacant, not connected)	
Pin 4	GND	
Pin 5	PWM+	Frequency control for laser
Pin 6	NC (vacant, not connected)	
Pin 7	LASER or GATE signal	On/Off optical signal, must be connected, otherwise it will not work properly
Pin 8	NC (vacant, not connected)	
Pin 9	NC (vacant, not connected)	

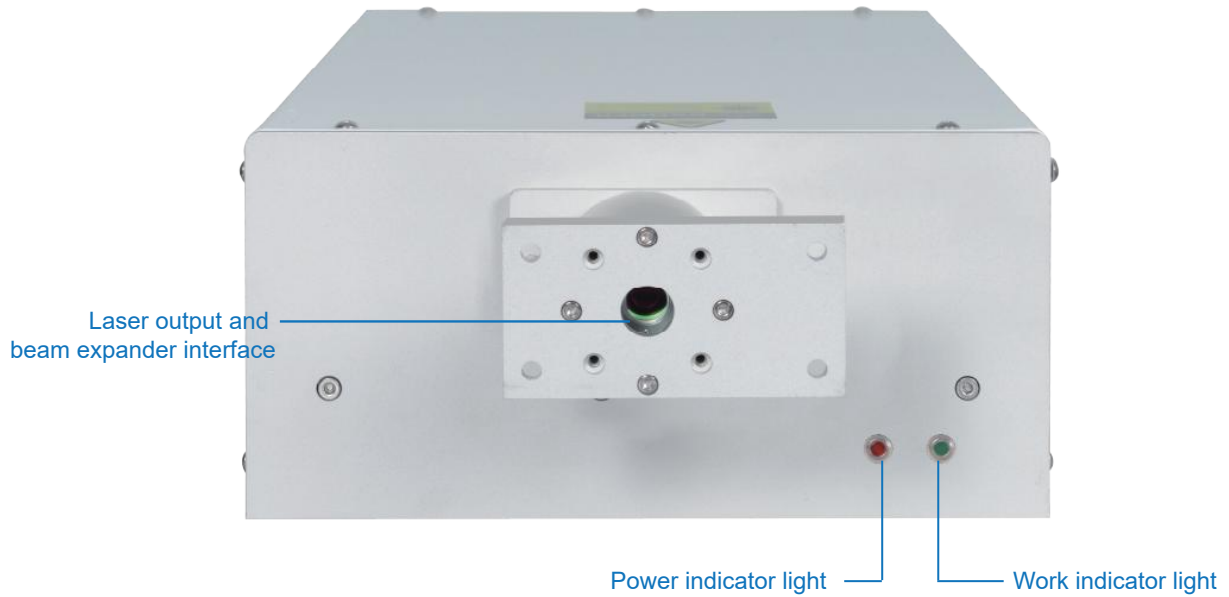

- **Power indicator light**

Red - When the indicator lights up, it means the laser is powered on, but cannot judge whether the laser is on or off. Take great care at all times when using the laser. When the indicator light is off, it means that the laser is not powered on. At this time, the laser is in the off state.

- **Work indicator light**

Green - When the indicator lights up, it means that the laser can work normally, but cannot judge whether the laser is on or off. Take great care at all times when using the laser. When the indicator light is off, it means that the laser is not ready. At this time, the laser is in the off state.

- **Laser output and beam expander interface**

Laser output port. The laser outlet is fitted with a beam expander mirror, replaceable by the user. Note that the beam expander mirror needs to be replaced in a clean, airless environment to prevent contamination of the laser's internal window mirror.

## 2.4 Installation Instructions

### 2.4.1 Installation Method of Laser

#### Installation process

- Install the fixed feet outward to the bottom of the laser;
- Install the laser on the laser equipment.

**Remark:** the mounting surface should be flat to ensure that the laser fixed feet fully fit the surface.

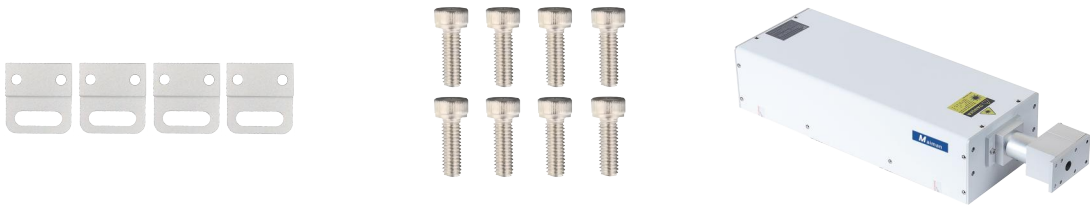

Fixed feet, Screws, The laser ▲



Bottom view of the laser after the fixed feet are installed ▲



Install the fixed feet on to the laser ▲

## 2.5 Dimensional Drawing

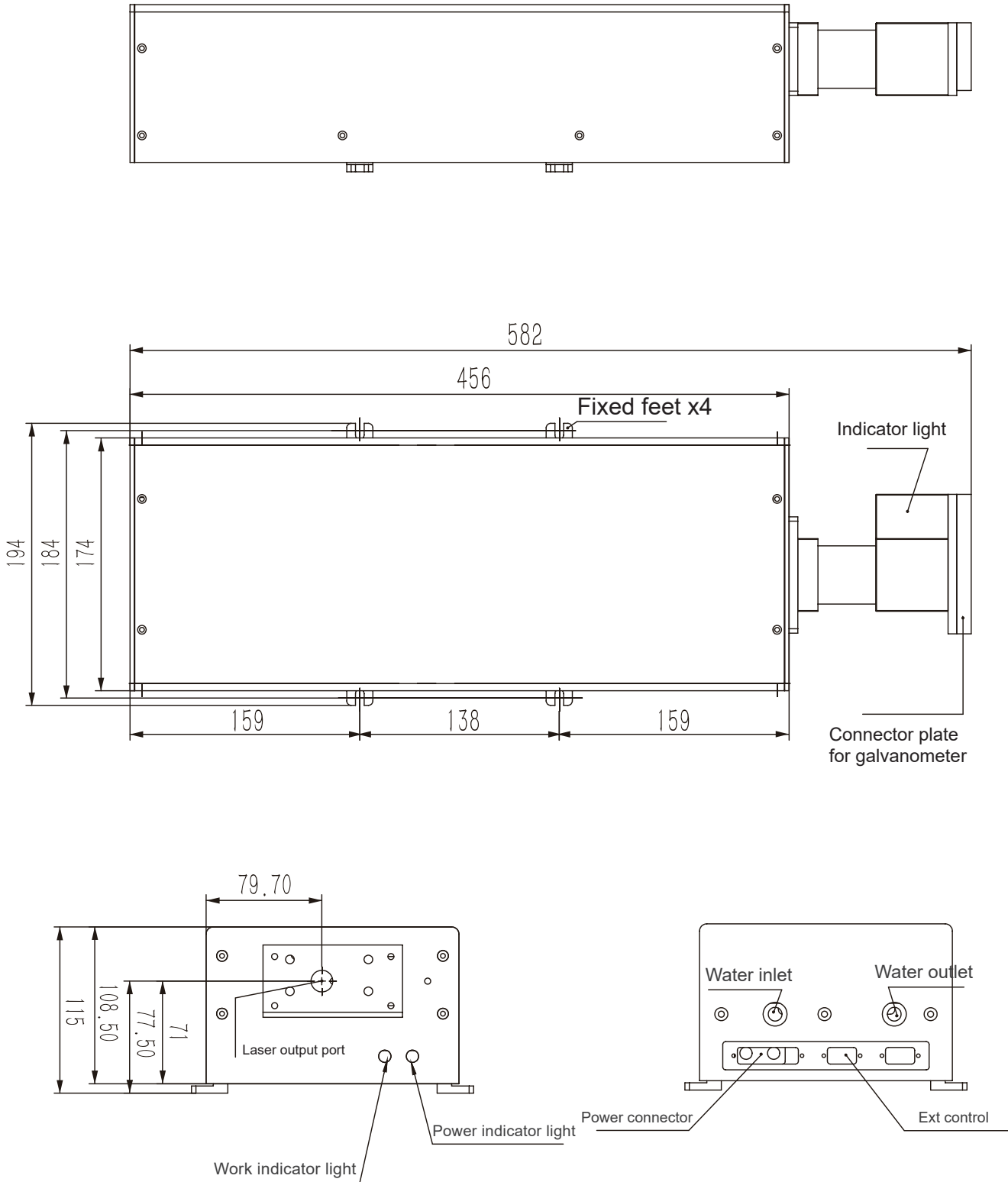

### 3. Laser Operation Instructions

#### 3.1 Startup Process

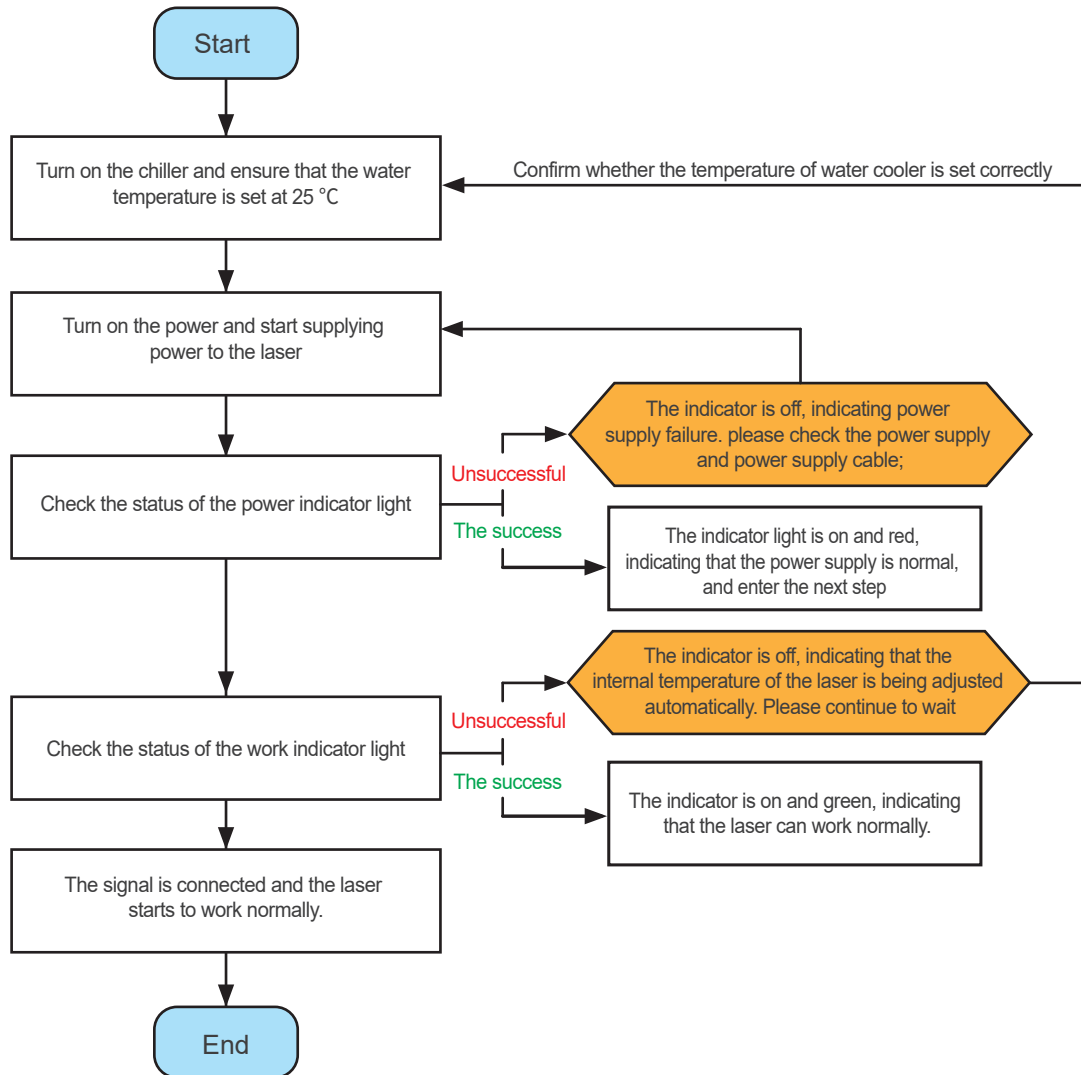

**⚠ Notice:**

- Check the external environment before starting the laser, and make sure that the power, cooling water and protection system are all normal before running the laser device.
- Before starting, Check and make sure that all interfaces are installed correctly without looseness. When the laser is working, do not unplug the connection between the switching power supply and the laser, otherwise the laser will be burned directly. If the cable is found to be loose or not connected, please turn off the power first, and then fasten or connect it.
- It takes 5 minutes to start up the device. After the power is turned on, the red indicator light on, which means the laser power supply is normal at this time; the green indicator light on, which means that the laser system is ready and can work normally.

### 3.2 Shutdown Process

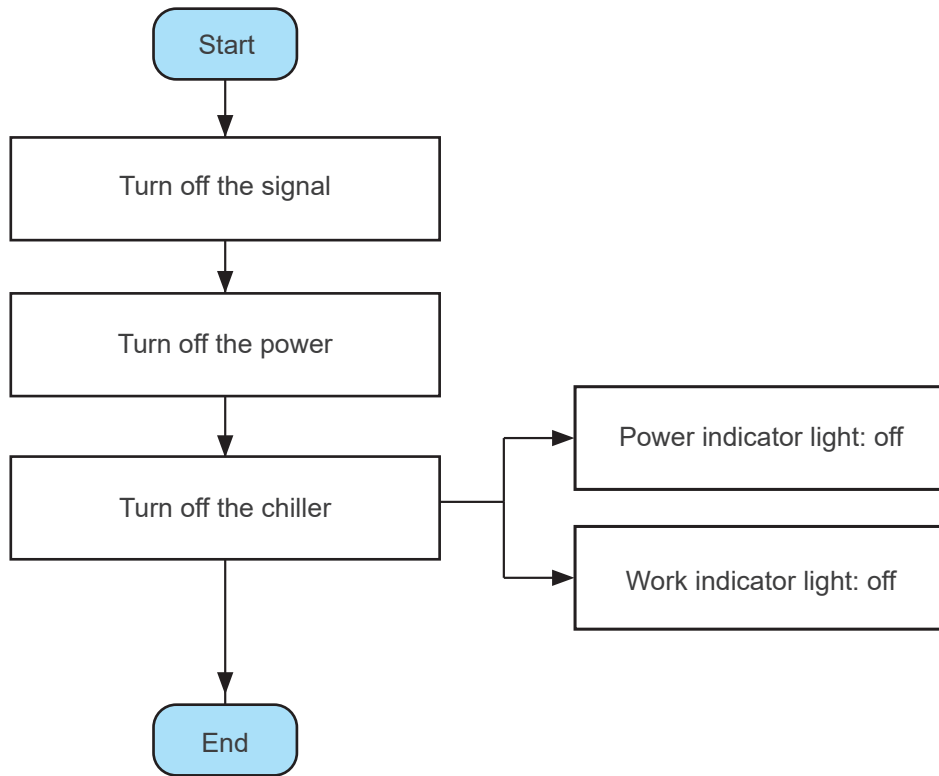

**⚠ Note:**

- Do not turn off the chiller before turning off the power; turning off the chiller first may cause the device to burn out.

## 4. Connection with Common Systems and Software Settings

The connection and software settings with the control systems of EzCad, Central-laser, BSL, and Earain are listed below, and laser control can be realized according to this operation. Please contact the companies directly for more details of control system.

- ☆ CO2 control mode and YAG control mode are optional
- ☆ CO2 control mode is recommended, which is simpler and easier to understand.
- ☆ The wiring of the two control modes are exactly the same.

### 4.1 The Interface Diagram and Software Settings of EzCad Control Board

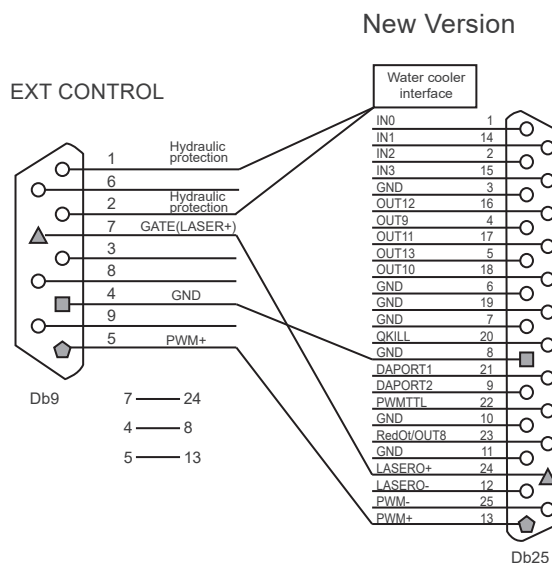
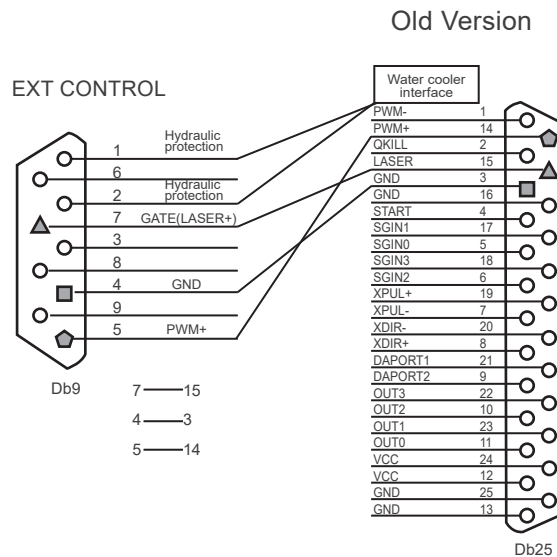

EzCad Control Board setting example:

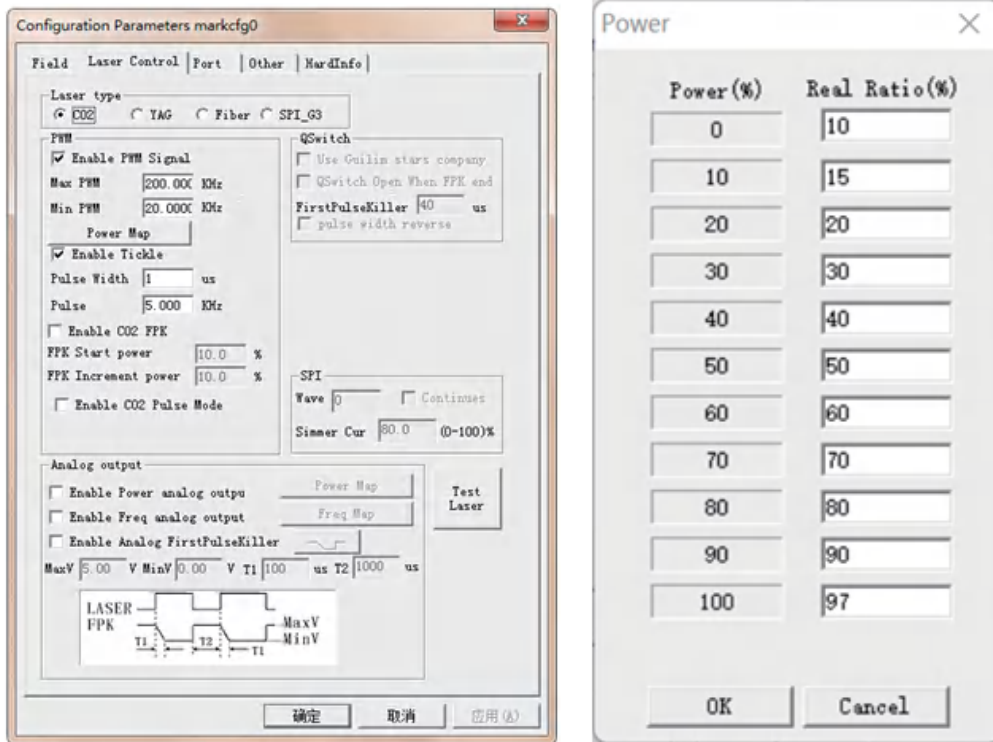

★ Note: The laser can be controlled by CO2 mode. Take the EzCad Control Board as an example, the settings are as shown in the picture above, select the CO2 control mode, and then click the "Power Map" button to set as shown in the picture above, so the maximum Real Ratio(%) is 97. Do not check the "Enable Tickle" option, otherwise it will cause laser leakage.

⚠ Warning: If you purchase a laser controlled by CO2 mode, please use a CO2 control board to cooperate with it!



## 4.2 The Interface Diagram and Software Settings of Central-laser Control Board

### Markingmate series UMC4 control board

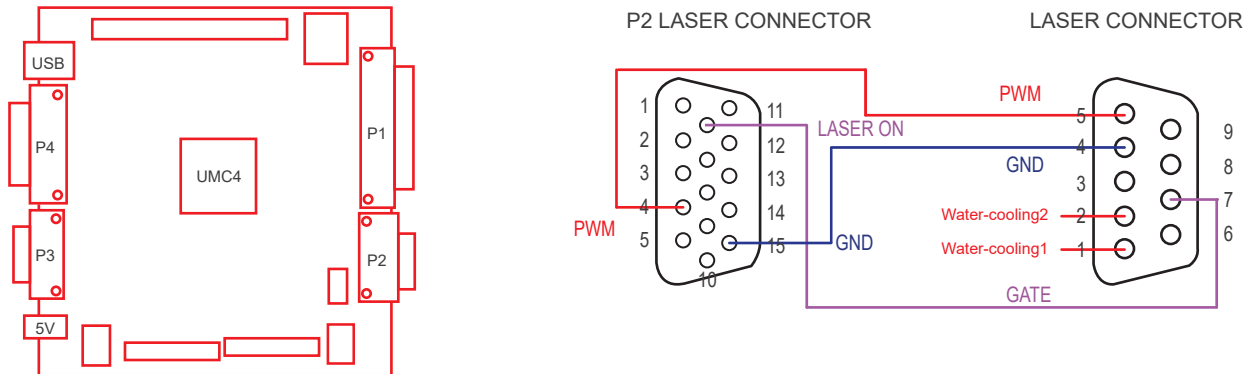

Drive selection: Select CO2 mode for Maiman UV laser drive

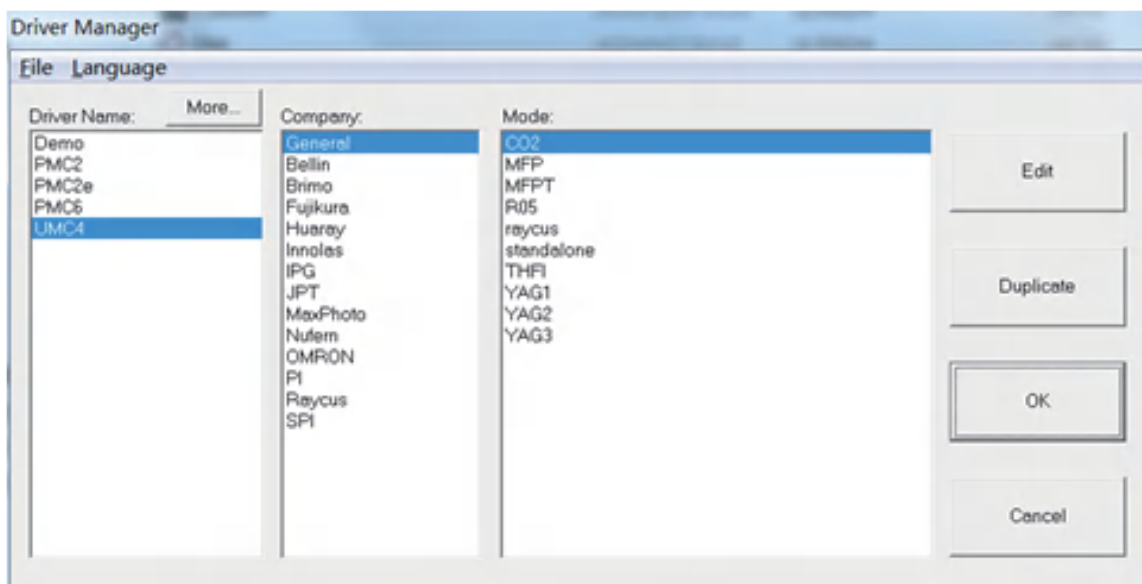

NMC Touch Screen Flying Series MC3 Control Board Wiring:

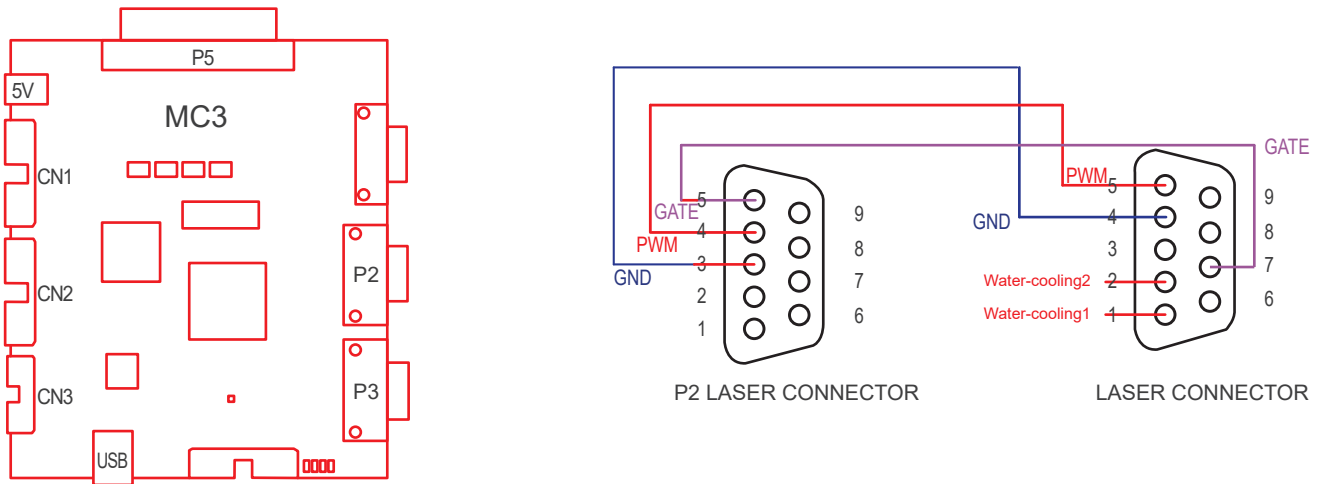

Drive selection: Select CO2-laser-Ky for Maiman UV laser drive

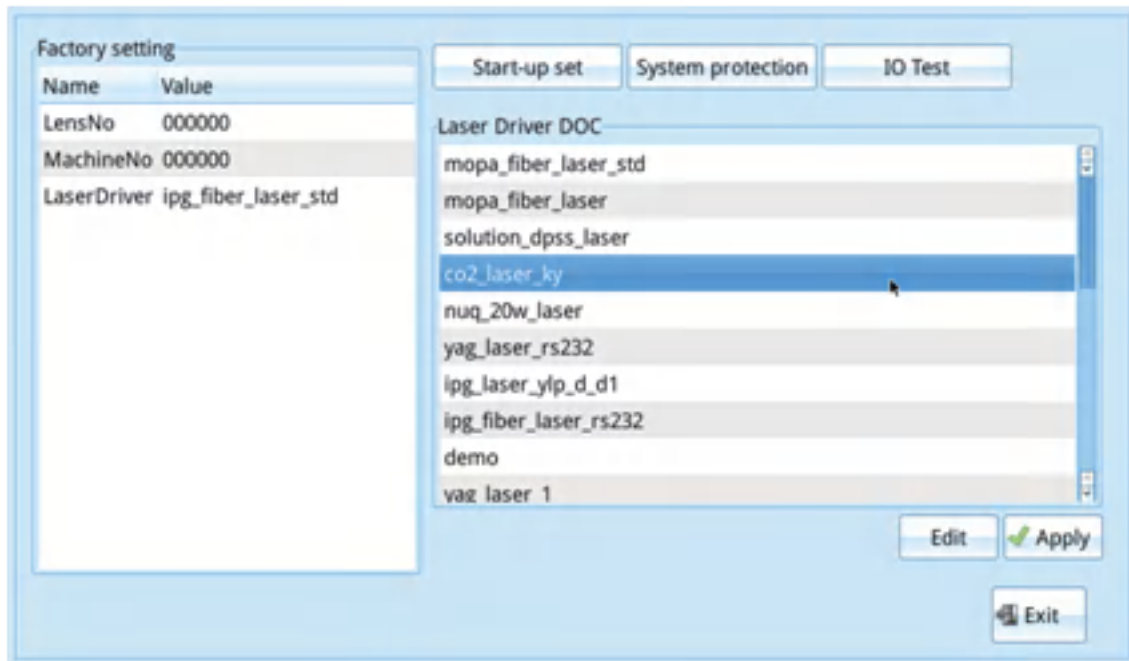

### 4.3 The Interface Diagram and Software Settings of BSL Control Board

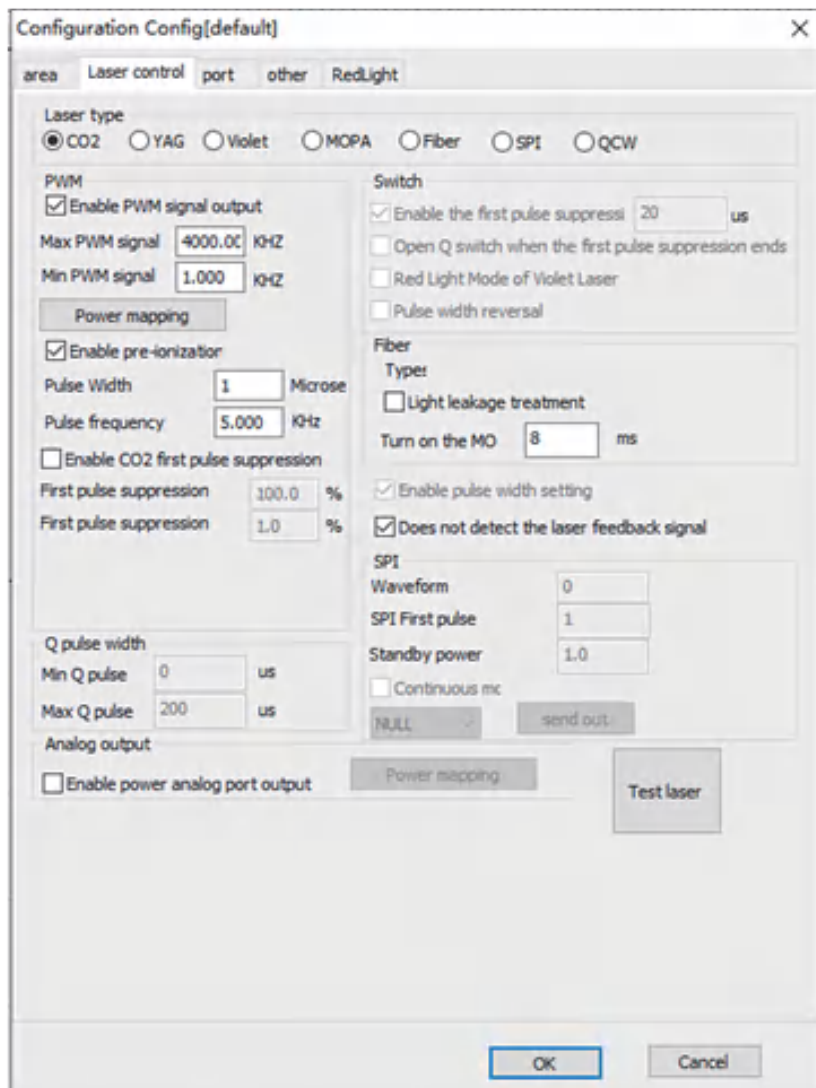
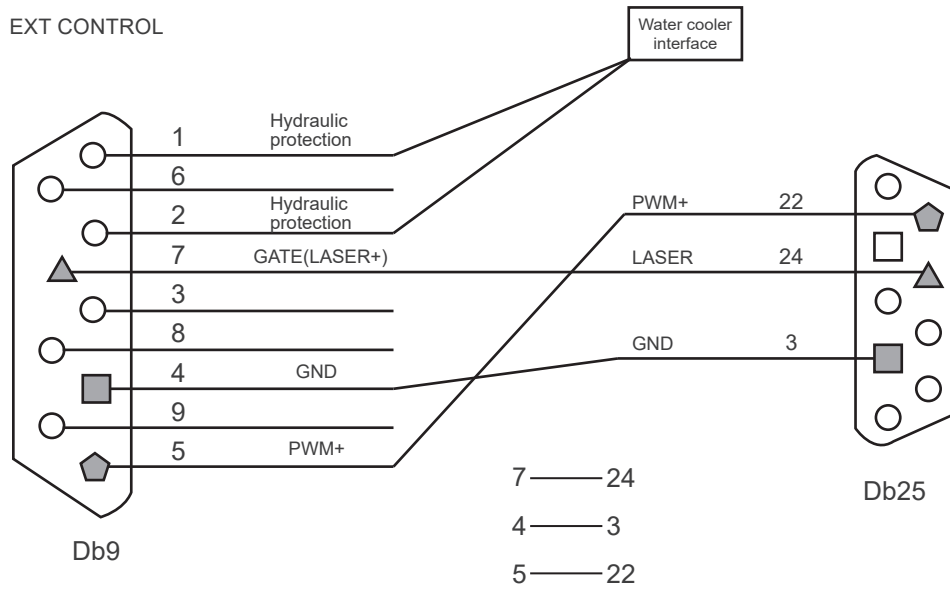

### 4.4 The Interface Diagram and Software Settings of Earain Control Board

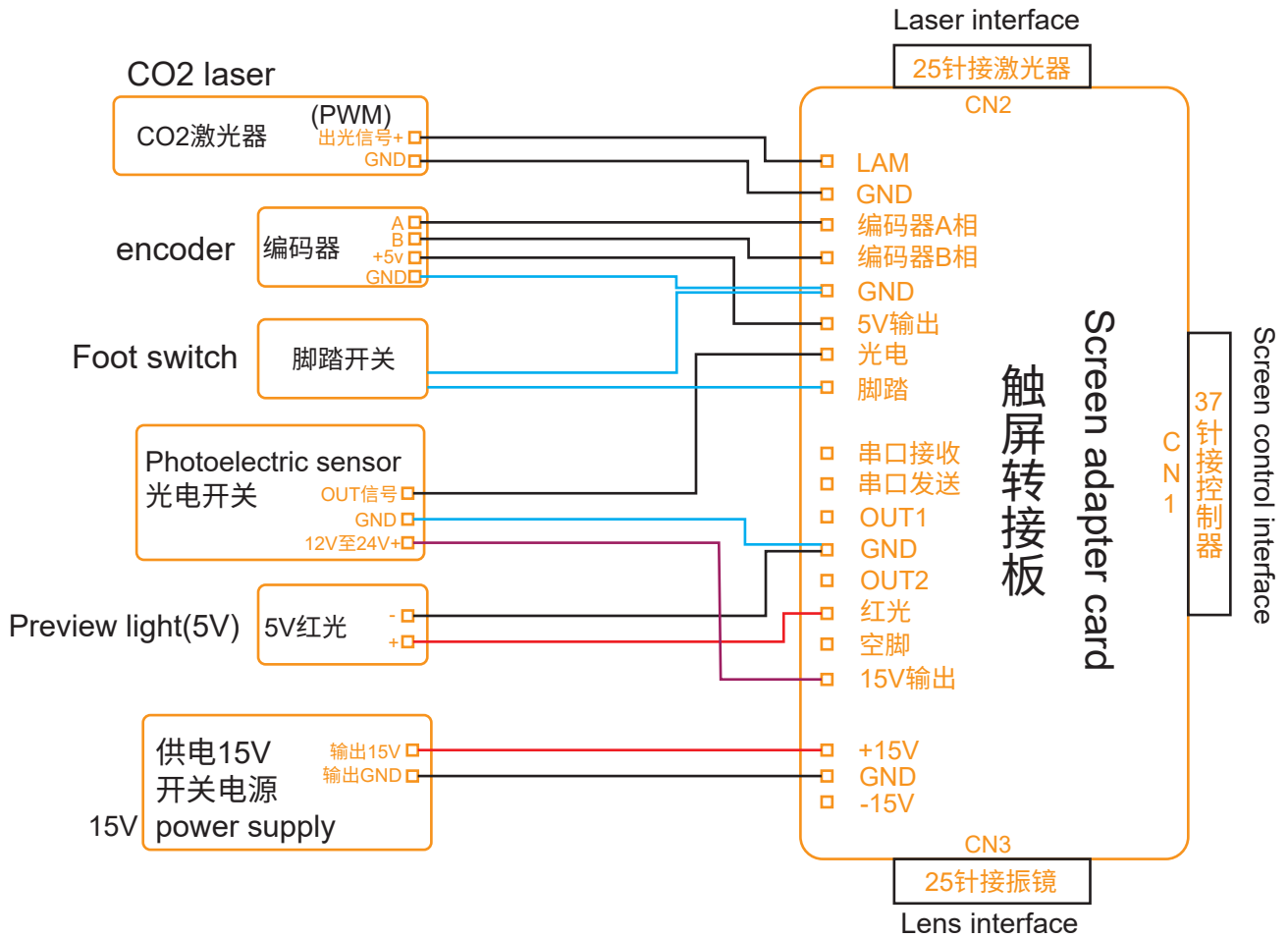

## 5. Troubleshooting and Maintenance

### 5.1 What should I do if the laser does not emit laser?

- Check whether the chiller is running or not and whether the set temperature is correct or not.
- Check whether the water pressure protection cable is connected or not. After the chiller starts up, the water pressure protection cable should be in a short-circuit state. Users can measure whether the water pressure signal line is normal or not with a multimeter.
  - The cooling power of the chiller is too small to keep the laser at 25°C, and the temperature fluctuates greatly.
  - The power supply is on or off, the red indicator light on the laser should be on after the power supply is on.
  - Whether the system has entered the working state or not, if the laser system is ready, the green indicator lights on before the laser can work normally.
- Check whether the control signal is correct or not; whether a CO<sub>2</sub> control board is used or not, be aware that the fiber control board cannot control the laser; if the control board is confirmed to be correct, please check whether the "PWM+ signal" and "On/Off optical signal" are connected correctly or not. Use a multimeter to check: switch the multimeter to the DC voltage, set the power to "50" on the marking software, and then perform continuous marking. At this time, the PWM+ signal should have a voltage output of about 2.5V, and the "On/Off optical signal" voltage should be 5V, and then set the power further to "90" to continuously mark. At this time, the PWM+ signal should have a voltage output of about 4.2V, and the "On/Off optical signal" voltage should be still 5V, which means the signal is normal. If an oscilloscope is available, it is more accurate to use an oscilloscope to do the check.
  - Check whether the terminals of the signal cable are soldered correctly or not. The 4-pin of the laser to be connected to the GND of the control board; the 5-pin to connected to the PWM+ signal of the control board, and the 7-pin connected to the On/Off optical signal of the control board.
  - Check whether the plug of signal cable is firm or not.

### 5.2 The laser intensity becomes weak after working for a period of time?

- Whether the chiller is on or not.
- Whether the working temperature is normal or not.
- Whether the water level of the chiller is too low or not.
- Whether the field lens and galvanometer are polluted or not.

## 6. After sale service

### 6.1 Warranty

All laser source products from Tianjin Maiman Laser Technology Co., Ltd. come with an 18-month warranty period, which certifies that your laser is found to be free of any defects in material or workmanship. This warranty applies regardless of your laser application. It does not cover any issues that may arise due to operator negligence, environmental factors, accident, alterations, or improper maintenance. Tianjin Maiman Laser Technology Co., Ltd maintains the sole authority to make any claims or statements regarding warranty on its products. Maiman Laser reserves the right to make changes or improvements to product design without notice, and without expectation of equivalent changes in products previously manufactured or shipped.

### 6.2 Returns

If a failure should occur, please contact [maimanlaser@maimanlaser.com](mailto:maimanlaser@maimanlaser.com) or +86 17526524352. If a laser or accessories needs to be returned, a Return Merchandise Authorization(RMA) will be issued. Any laser returned without an RMA will be at your sole expense.

Typically, for failure within the 18 months, the client shall be responsible for shipping costs to Tianjin Maiman Laser Technology Co., Ltd. or its distributors. Maiman Laser or its distributors will pay all shipping costs to return the item(s) to the client.

When requesting an RMA please have the following information ready:

Date of purchase:

Date of receiving the laser:

Laser Model:

Date the issue was first discovered:

Brief description of the issue:

Find out the RMA as completely as possible. For any returns, please ship the item(s) to:

Tianjin Maiman Laser Technology Co., Ltd.

Attn: Overseas Department, Lynn Zhang

201, D6-A, East Huigu Industrial Park, Xiqing District, Tianjin, China

Include the laser and all accessories when returning the laser. This allows Maiman Laser to determine the source of the issue.

## Tianjin Maiman Laser Technology Co., Ltd.

Address: 201, D6-A, East Huigu Industrial Park, Xiqing District, Tianjin

Tel: +86-22-8789 4207 8789 4217

Mobile: +86-22 175 2652 4352

Fax: +86-228789 4217

Web: [www.maimanlaser.com](http://www.maimanlaser.com)

E-mail: [maimanlaser@maimanlaser.com](mailto:maimanlaser@maimanlaser.com)



[View website](#)



[View catalog](#)



WhatsApp

Tianjin Maimanlaser Technology Co., Ltd. reserves the copy right of this catlog and reserves all the rights to change the information and specifications contained in this catlog without prior notice.

Version updated on June 6th, 2024.