

Maiman

Superb Technology & Optimum Quality

Stone & Stone Plus Series

air-cooled UV laser

Instruction manual

VN: USL20240416



Tianjin Maiman Laser Technology Co., Ltd.

Preface

This manual is applicable to engineers who have basic knowledge of hardware and have a certain understanding of laser equipment and device. Please read through this manual carefully before using the Maiman laser products and keep it properly. If you have any questions, please contact Tianjin Maiman Laser Technology Co., Ltd.

For more product and information, please visit our website
www.maimanlaser.com



Content

1. Maiman Laser Safety Instructions	01
1.1 Declaration of Safe Use	01
1.2 Safety and Warning Signs	01
1.3 Guidelines for Safety Operation of the Laser	02
1.4 Product Safety Features	02
2. Product Installation Instructions	03
2.1 Laser Installation and Service Conditions	03
2.2 Supplied Accessories	04
2.3 Description of Laser Interface	05
2.4 Installation Instructions	07
2.4.1 Installation Method of Laser	07
2.5 Dimensional Drawing	08
2.6 Instruction of RS232 Control Mode	09
2.6.1 Software Installation	09
2.6.2 Software instructions	09
2.6.3 Description of software interface features	10
2.7 UVM-01C Interface Card Protocol Description	11
2.7.1 Parameterization of the RS232 interface	11
2.7.2 Description of the communication protocol	11
2.7.3 RS232 command sheet	12
3. Laser Operation Instructions	14
3.1 Startup Process	14
3.2 Shutdown Process	15
4. Connection with Common Systems and Software Settings	16
4.1 The Interface Diagram and Software Settings of EzCad Control Board	16
4.2 The Interface Diagram and Software Settings of Central-laser Control Board	18
4.3 The Interface Diagram and Software Settings of BSL Control Board	20
4.4 The Interface Diagram and Software Settings of Earain Control Board	21
5. Troubleshooting and Maintenance	22
5.1 What should I do if the laser does not emit laser	22
5.2 The laser intensity becomes weak after working for a period of time	22
6. After sale service	23
6.1 Warranty	23
6.2 Returns	23

1. Maiman Laser Safety Instructions

1.1 Declaration of Safe Use

The manual must be read through carefully before using the Maiman laser, and operators must operate in strict accordance with the guidelines of the manual, so as to avoid the damage to the human body and property caused by improper operation. If the operator does not use the product in accordance with the guidelines of the manual, Tianjin Maiman Laser Technology Co., Ltd will not bear any legal responsibility for all personal and property damages arising therefrom.

1.2 Safety and Warning Signs/Labels

	<p>Laser radiation warning sign Viewing visible or invisible laser light emanating from the laser will cause serious injury and potential blindness, as is reflected, scattered, and diffuse light.</p>
	<p>Safety Warning sign The specific procedures need to be followed, otherwise your device or parts may be damaged or will bring danger. You need to follow specific procedures, otherwise your equipment or components may be damaged or dangerous.</p>
	<p>The production label</p>
	<p>Anti disassembly label I . No warranty if the label is damaged.</p>
	<p>Anti disassembly label II .No warranty if the label is damaged.</p>
	<p>Maiman's logo</p>
	<p>QR code</p>



1.3 Guidelines for Safety Operation of the Laser

- The laser products of our company belongs to class IV laser device ($>500\text{mw}$) according to its output power level, The laser radiation will cause serious harm to human body, as well as fire and other hazards. Only qualified personnel who have been trained and are well aware of the danger of laser are allowed to operate this product. Non operators should evacuate outside the danger area of laser radiation.
- Do not open the casing of the laser body under any circumstances.
- Establish a safe operation area around the laser and take necessary measures to prevent the leakage of the laser. Post Class IV laser warning signs and safety warning signs at obvious positions in the safe operation area to prevent untrained personnel from entering.
- Store the laser in a place with certain power protection conditions, and all parts of the laser should have good grounding protection.
- Wear professional laser protective glasses, gloves, protective clothing, etc. during operation. Do not look at the laser beam directly without protective measures, do not touch the laser beam directly to avoid damage to eyes, skin, clothing, etc.
- Do not wear jewelry or any reflective objects, and do not irradiate the light beam on the reflective surface, so as to avoid personal injury caused by the reflected light.
- Take measures to block the reflected beam, or use a working platform with CLASS IV protection grade when processing metal parts which may reflect beam strongly.
- Keep the laser beam above or below the human eyes during operation, do not keep it on the same level as the human eyes.
- If volatile substances are used in the laser operation area, cleaned them out of the operation area immediately after the operation.
- After operation, the operator should check with the UV fluorescent sheet to confirm that the laser has been turned off before leaving.
- The maintenance and repair of the device should be carried out by professionally trained personnel. Be sure to refer to the relevant contents in the manual.

1.4 Product Safety Features

- Power indicator light: Red - When the indicator lights up, it means the laser is powered on, but cannot judge whether the laser is on or off. Take great care at all times when using the laser. When the indicator light is off, it means that the laser is not powered on. At this time, the laser is in the off state.
- Work indicator light: Green - The indicator light is always on, indicating that the laser can work normally, and the indicator light flashes, indicating that the laser is in standby mode. However, neither of these two states can determine whether the laser is on or off. When using the laser, you need to be very careful at all times. When the indicator light does not light up, it means that the laser is not ready yet. At this time, the laser is turned off.

2. Product Installation Instructions

2.1 Laser Installation and Service Conditions

- do not power on the laser during installation and disassembly, otherwise the laser will be burned; at the same time, pay attention to anti-static to avoid electrostatic breakdown of the internal laser diode;
- The working temperature of the laser is -5 °C- 40 °C, and too high or too low temperature will weaken the laser power;
- Replace the beam expander in a relatively clean environment without air flow to prevent dust from polluting the window mirror;

Remarks: beam expanders and window mirrors are not covered by warranty;

- The laser power supply is a special switching power supply. Use the laser's own switching power supply. Do not replace it without permission. Connect the laser power supply cable correctly, otherwise the laser will be burned directly;
- Pay attention to the cleanliness of the fan. Excessive dust can easily cause blockage of the air duct inside the laser.
- Laser damage caused by human factors is not within the scope of warranty;
- No warranty if the anti disassembly label is damaged.

Category	Item	Specification
Electrical requirements	Switching power supply input voltage	AC100-240V, 50-60Hz
	Switching power supply output voltage/current	DC12V, 29A
	Laser input voltage/current	DC12V, 29A
	Running power	350W
Environmental requirements	Storage temperature	-10-40 C
	Storage humidity	<90%(No condensation)
	Operating temperature	-5-40 C
	Operating humidity	<80%(No condensation)
	Dust	< 0.20mg/m ³
	Oil mist	Non
	Electromagnetic environment	GB Calss II
Shock	Isolate vibration sources	

2.2 Supplied Accessories

No.	Item	Picture	Qty	Unit	Description
1	Stone/Stone Plus air-cooled series laser		1	set	3W/5W/8W
2	Galvanometer adapter plate		1	piece	9.6cm*4.7cm
3	Switching power supply		1	piece	LRS-350-12
4	Power supply cable		1	piece	3*2.5,2m
5	Fixed foot		3-4	piece	M4
6	9-pin plug		1	set	DB9 pin
7	9-pin housing		1	set	DB9 pin shell
8	Galvanometer adapter plate screws		4	piece	M5*12
9	Fixed feet screws		6-8	piece	M4*10

Remark: • The photos are for reference only, and the real object shall prevail.

2.3 Description of Laser Interface

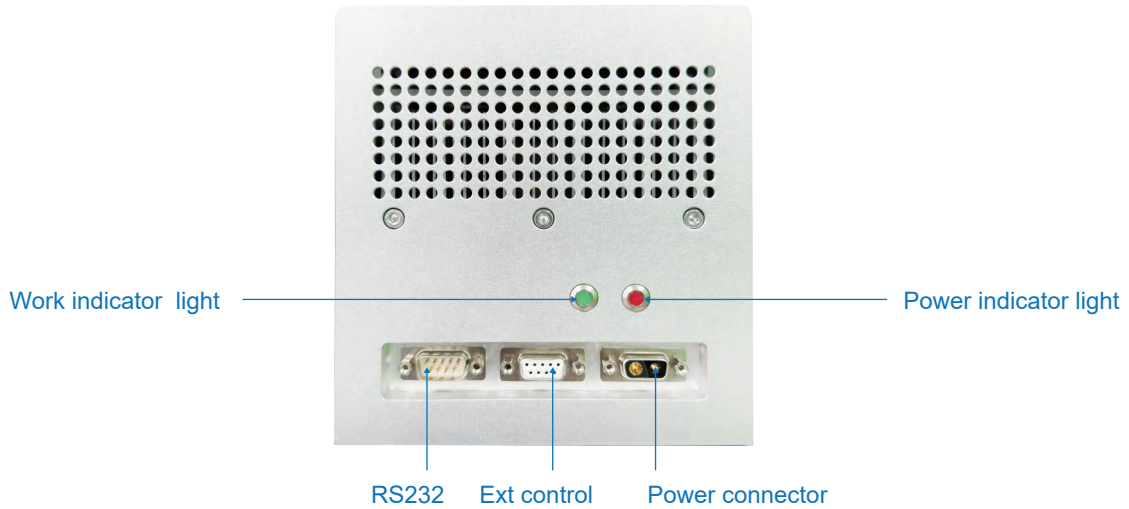

• Power connector

Provides DC constant voltage power supply for the laser. The laser is powered by the attached power supply cable and AC-DC switching power supply. Pay attention not to short circuit or connect incorrectly during wiring, otherwise the laser will be burned directly;

• Ext control

Control laser output and parameter adjustment. It is the external control interface (pin DB9), which is connected with the control board and the water pressure protection signal of the chiller, as defined below:

No.	Item	Description
Pin 1	NC (vacant, not connected)	
Pin 2	NC (vacant, not connected)	
Pin 3	NC (vacant, not connected)	
Pin 4	GND	
Pin 5	PWM+	Frequency control for laser
Pin 6	NC (vacant, not connected)	
Pin 7	LASER or GATE signal	On/Off optical signal, must be connected, otherwise it will not work properly
Pin 8	NC (vacant, not connected)	
Pin 9	NC (vacant, not connected)	

• Power indicator light

Red - When the indicator lights up, it means the laser is powered on, but cannot judge whether the laser is on or off. Take great care at all times when using the laser. When the indicator light is off, it means that the laser is not powered on. At this time, the laser is in the off state.

- **Work indicator light**

Green - The indicator light is always on, indicating that the laser can work normally, and the indicator light flashes, indicating that the laser is in standby mode. However, neither of these two states can determine whether the laser is on or off. When using the laser, you need to be very careful at all times. When the indicator light does not light up, it means that the laser is not ready yet. At this time, the laser is turned off.

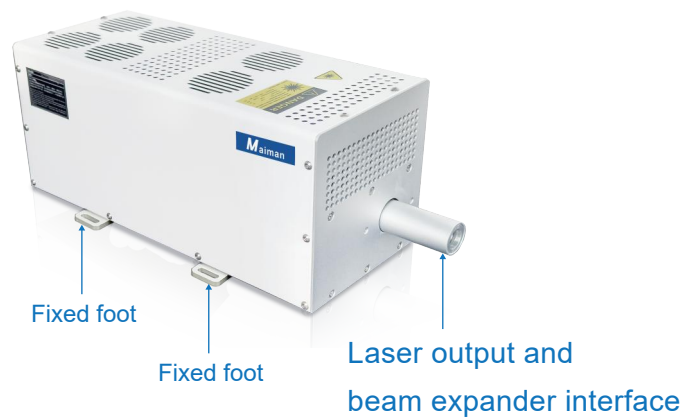

- **Laser output and beam expander interface**

Laser output port. The laser outlet is fitted with a beam expander mirror, replaceable by the user. Note that the beam expander mirror needs to be replaced in a clean, airless environment to prevent contamination of the laser's internal window mirror.

- **Fixed feet**

Fix the laser.

2.4 Installation Instructions

2.4.1 Installation Method of Laser

Installation process

- Install the fixed feet outward to the bottom of the laser;
- Install the laser pallet on the marking machine bracket;
- Fix the laser on the pallet and complete the installation of the laser.



Fixed feet、Screws、The laser ▲



Bottom view of the laser after the fixed feet are installed ▲



Install the fixed feet on to the laser ▲

2.5 Laser Dimensional Drawing

Front view

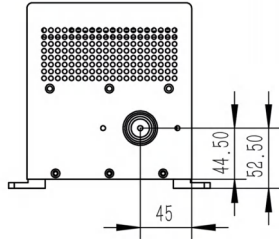

Back view

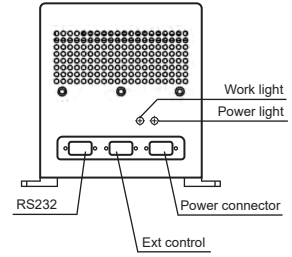

Side view

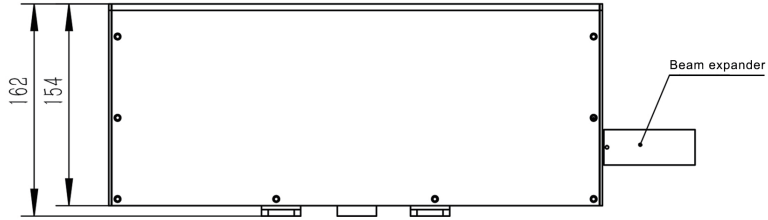

Vertical view

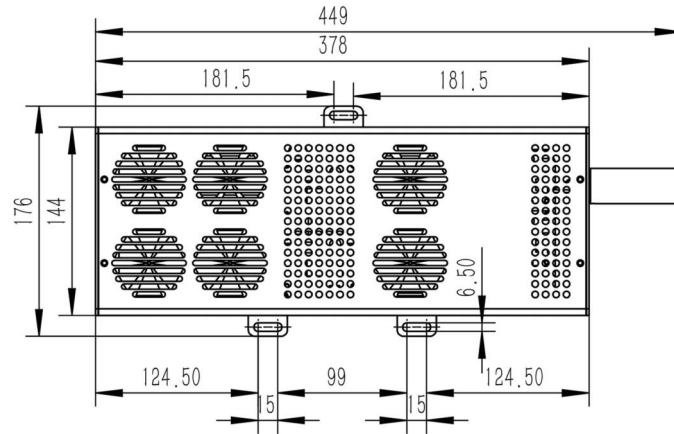

Bottom view

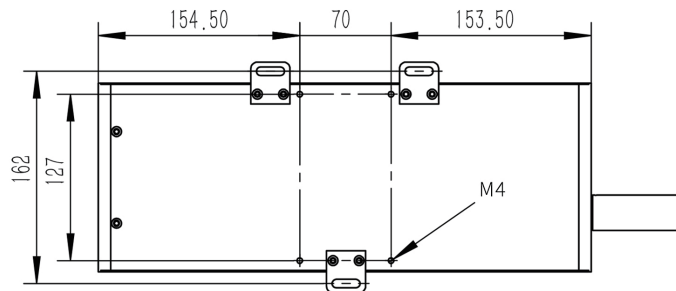

2.6 Instruction of RS232 Control Mode

2.6.1 Software installation

(1) Double-click  in the software package to install the software. The software is provided by Maiman. During the installation process, the anti-virus software needs to be stopped, otherwise the installation may fail;

(2) Install the RS232 driver, which is provided by the supplier of the RS232 data cable. The RS232 data cable connected to the Maiman laser is a USB to RS232 serial port 9-pin female;

2.6.2 Software instructions

(1) After the software is installed, click the shortcut  to enter the software interface, as shown in the picture below:

software interface:

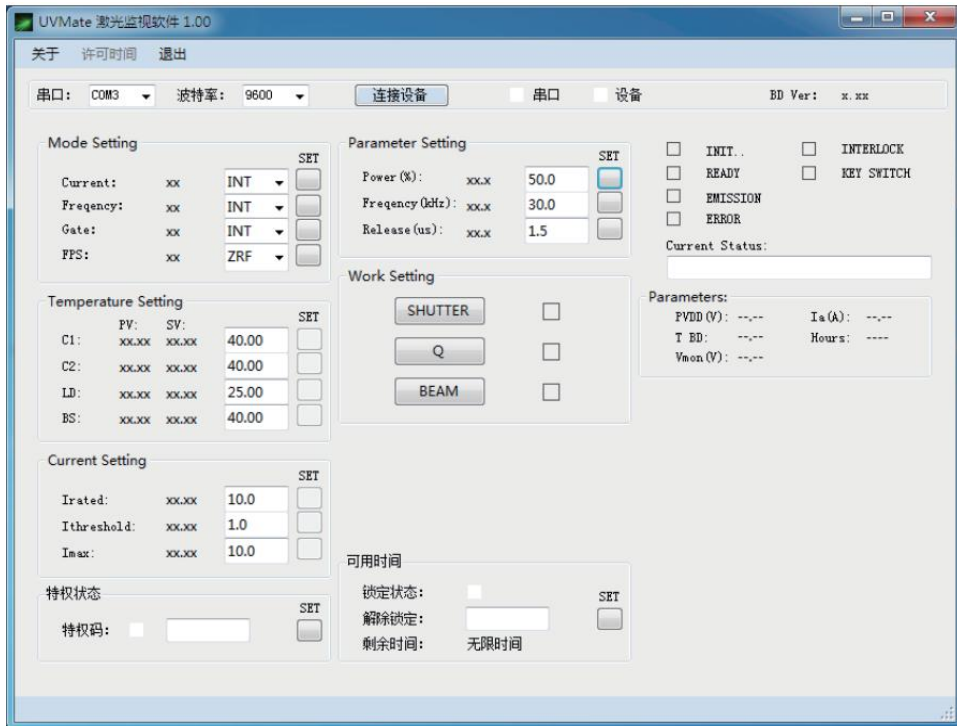

(2) Select the corresponding COM port and click Connect Device to connect it. After connecting, the serial port and device status box at the right end will become colored;

(3) Just select the corresponding parameter to set.



2.6.3 Description of software interface features

(1) This software can set a number of laser parameters, but not all parameters are open to the customer debugging, end customers can set the parameters are as follows (the rest of the parameters without the manufacturer's authorization, please do not change, otherwise it will affect the performance of the laser);

Frequency	Frequency control mode
Gate	Switching light control mode
FPS	First pulse control mode
Frequency(kHz)	Frequency setting
Release	PWM signal high time
BEAM	Light out/off in internal control mode

(2) Setting method and function description of common modes;

	Frequency	Gate	FPS
Default factory setting	Direct	EXT	PPK
No indicator light mode	EX/FW	EXT	ZRF
Internal control model	INT	INT	ZRF

(3) Default factory setting: the frequency and power of the laser are all determined by external signals, at this time, the greater the duty cycle of the signal, the higher the output power of the laser, and when there is no external signal input, the laser has a continuous indication of light output;

(4) No Indicator Light Mode: When there is no external signal input, there is no continuous indicator light output from the laser, other functions are the same as the default factory settings;

(5) Internal control mode: the frequency, power and whether the laser is out of the light is determined by the software, by setting the software interface parameters 'Frequency (kHz)' and 'Release' and to control the power, at this time, the higher the duty cycle of 'Release', the higher the output power of the laser, the parameter setting is completed, click the 'BEAM' button, the laser will be out of the light in accordance with the set parameters.



2.7 UVM-01C Interface Card Protocol Description

2.7.1 Parameterization of the RS232 interface

Parametric item	Request
Baud Rate:	9600
Data Bits	8
Stop bits	1
Parity	None
Flow Control	None
Termination Characters	\r\n (0x0D 0x0A)

2.7.2 Description of the communication protocol

(1) This communication protocol is an ASCII code communication protocol, and commands generally consist of several ASCII characters plus parameters.

(2) All commands and replies must be terminated with a 'carriage return line feed', i.e. 0x0D, 0x0A;

(3) The commands must be capitalized;

(4) A space may or may not be added between the command and the parameter;

(5) For each command, a reply will be generated, how the setting is valid will reply to the set value read, otherwise it will reply to null or ERR, and the read command will reply to the corresponding parameter value.

2.7.3 RS232 command sheet

Command	Description	Example
SPK	Set PulseKill mode Specification: SPKn "n" value: 0, 1 0: ZRF 1: PPK	Send: SPK0 Remove: 0
RPK	Read PulseKill mode	Send: RPK Remove: 0
SF	Set repetition rate Unit: Hz.	Send: SF 40000 Remove: 40000
SFM	Set Frequency mode Specification: SFMn "n" value: 0-3 0: INT 1: undefined 2: EXT/FW 3: DIRECT	Send: SFM 0 Remove: 0
RF	Read repetition rate	Send: RF Remove: 40000
RFM	Read Frequency mode	Send: RFM Remove: 0/1/2/3
SFR	Set Q discharge time Unit: 0.1us 15 mean 1.5us	Send: SFR 15 Remove: 15
RFR	Read Q discharge time	Send: RFR Remove: 15
SG	Set Beam(Gate) Light on/off Specification: SGn "n" value: 0, 1 1: on 0: off	Send: SG 1 Remove: 1
SGM	Set Gate Mode Specification: SGMn "n" value: 0, 1 0: INT 1: EXT	Send: SGM 1 Remove: 1
RG	Read Beam(Gate) statuses	Send: RG Remove: 1 1: light on 0: light off

RGM	Read Gate mode	Send: RGM Remove: 0/1
RSR	Read Ready signal	Send: RSR Remove: 1 1: Ready 0: --
RSM	Read Emission signal	Send: RSM Remove: 1 1: Emission 0: --

3. Laser Operation Instructions

3.1 Startup Process

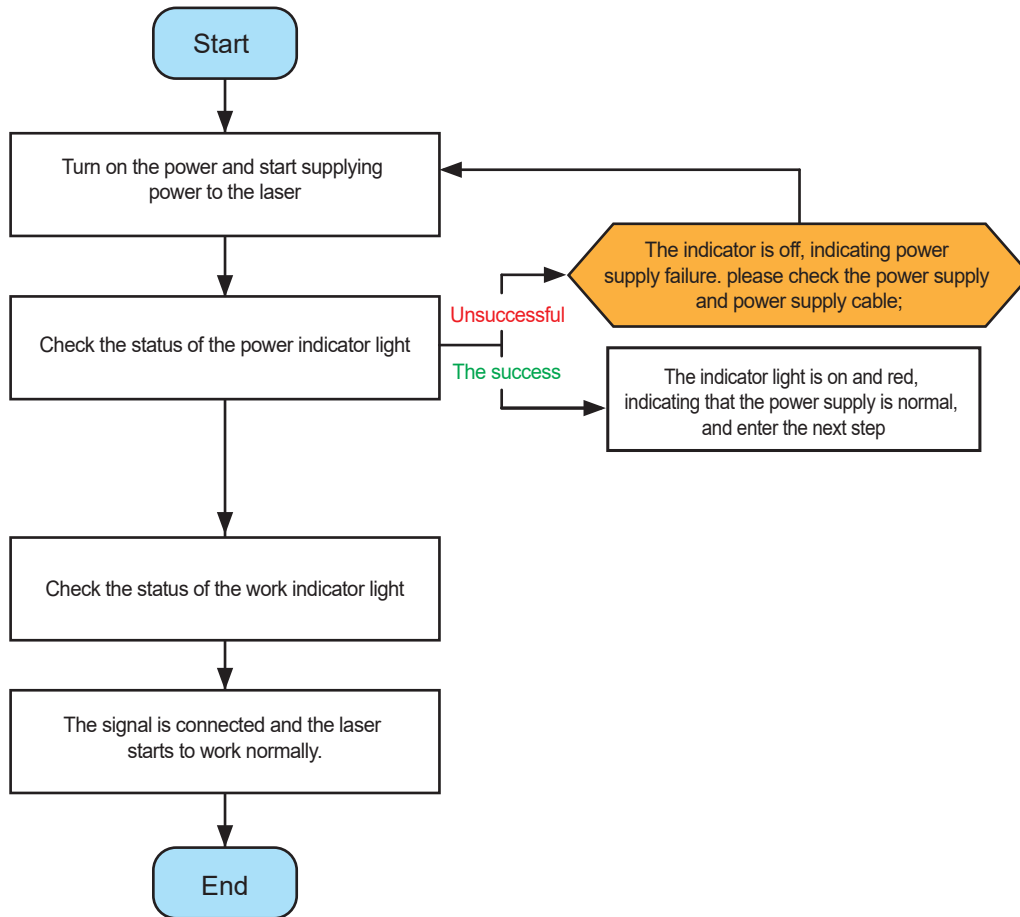

⚠ Notice:

- Check the external environment before starting the laser, and make sure that the power and protection system are all normal before running the laser device.
- Before starting, Check and make sure that all interfaces are installed correctly without looseness. When the laser is working, do not unplug the connection between the switching power supply and the laser, otherwise the laser will be burned directly. If the cable is found to be loose or not connected, please turn off the power first, and then fasten or connect it.
- It takes 5 minutes to start up the device. After the power is turned on, the red indicator light on, which means the laser power supply is normal at this time; the green indicator light blinking , which means the laser is in standby mode; the green indicator light on, which means that the laser system is ready and can work normally.

3.2 Shutdown Process

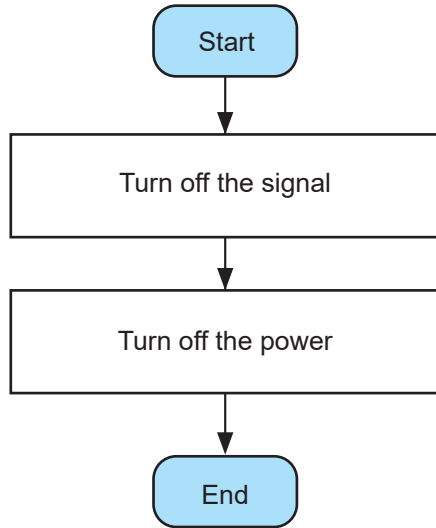

4. Connection with Common Systems and Software Settings

The connection and software settings with the control systems of EzCad, Central-laser, BSL, and Earain are listed below, and laser control can be realized according to this operation. Please contact the companies directly for more details of control system.

- ☆ CO2 control mode and YAG control mode are optional
- ☆ CO2 control mode is recommended, which is simpler and easier to understand.
- ☆ The wiring of the two control modes are exactly the same.

4.1 The Interface Diagram and Software Settings of EzCad Control Board

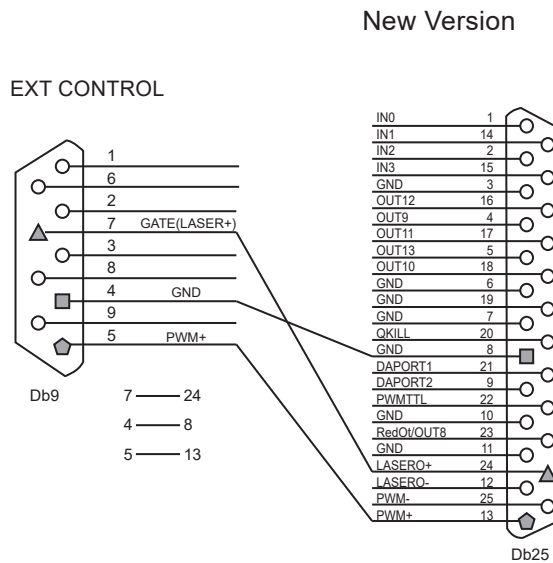
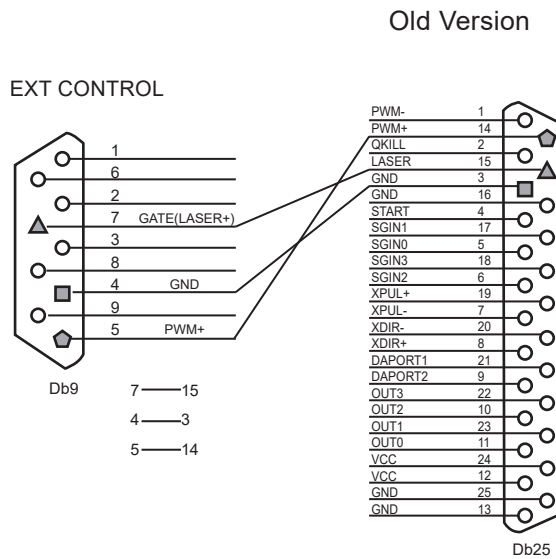

EzCad Control Board setting example:

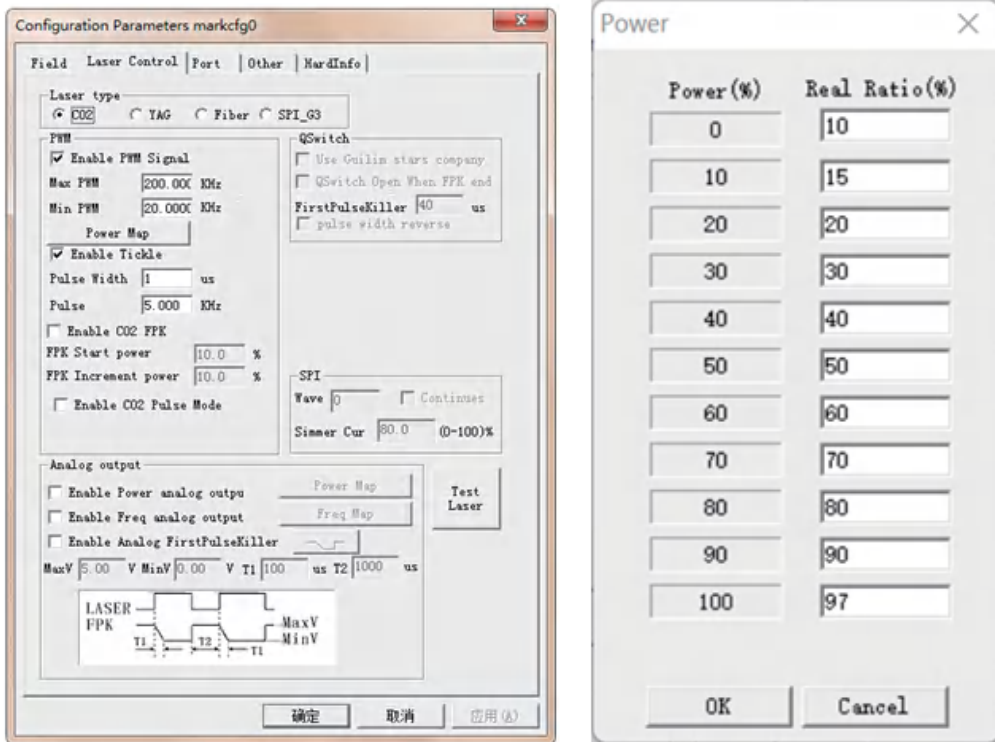

★ Note: The laser can be controlled by CO2 mode. Take the EzCad Control Board as an example, the settings are as shown in the picture above, select the CO2 control mode, and then click the "Power Map" button to set as shown in the picture above, so the maximum Real Ratio(%) is 97. Do not check the "Enable Tickle" option, otherwise it will cause laser leakage.

⚠ Warning: If you purchase a laser controlled by CO2 mode, please use a CO2 control board to cooperate with it!

4.2 The Interface Diagram and Software Settings of Central-laser Control Board

Markingmate series UMC4 control board

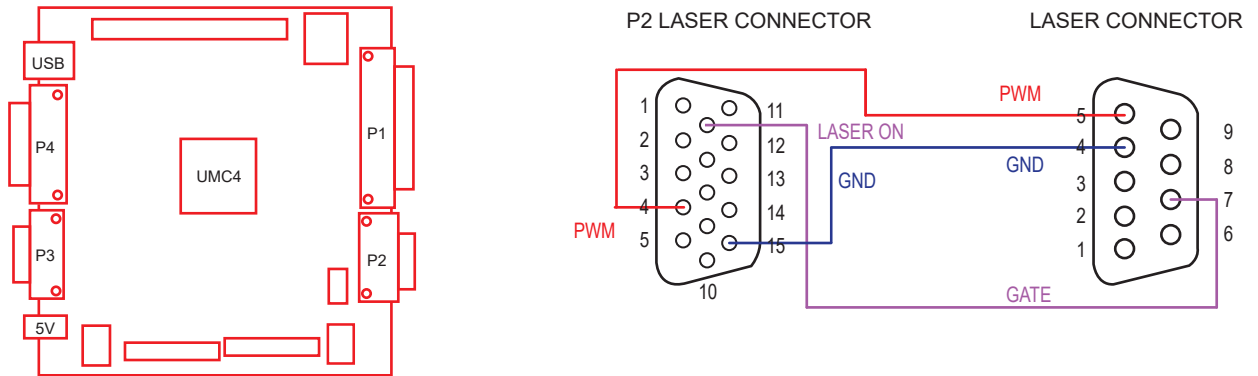

Drive selection: Select CO2 mode for Maiman UV laser drive

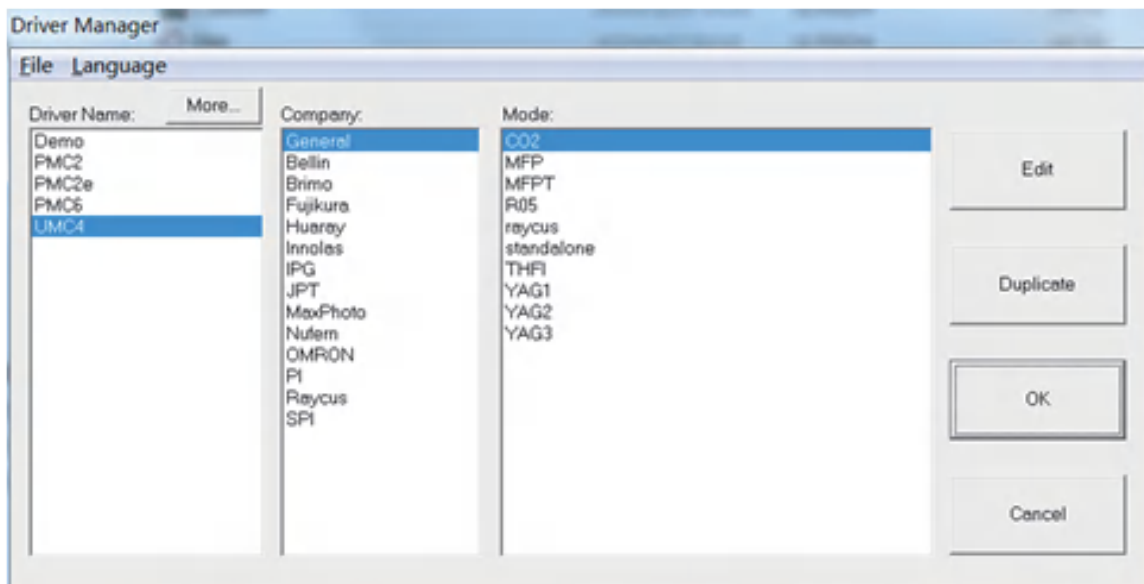

NMC Touch Screen Flying Series MC3 Control Board Wiring:

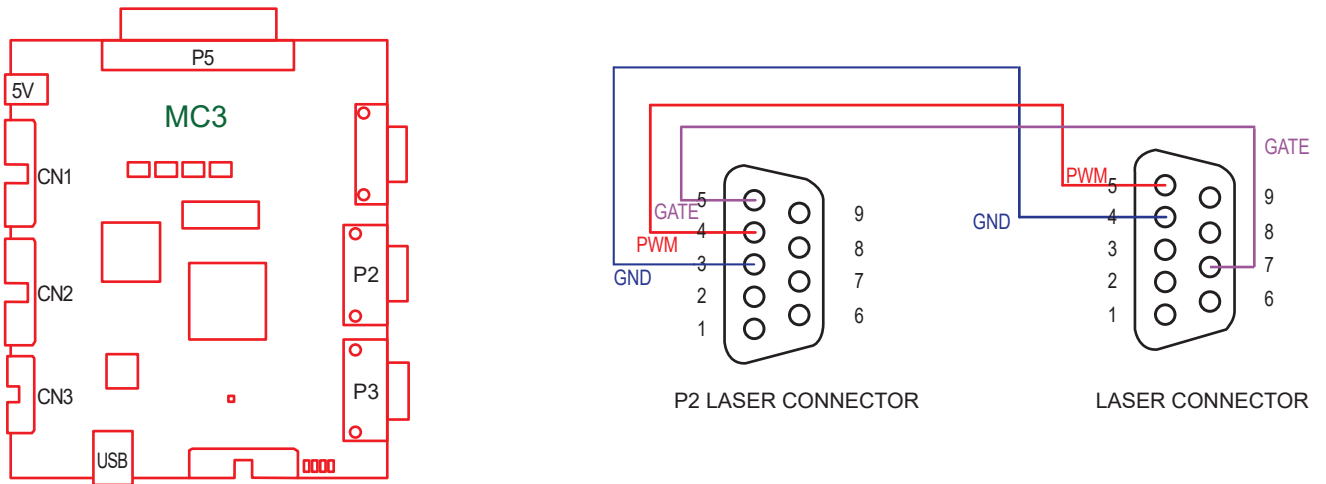

Drive selection: Select CO2-laser-Ky for Maiman UV laser drive

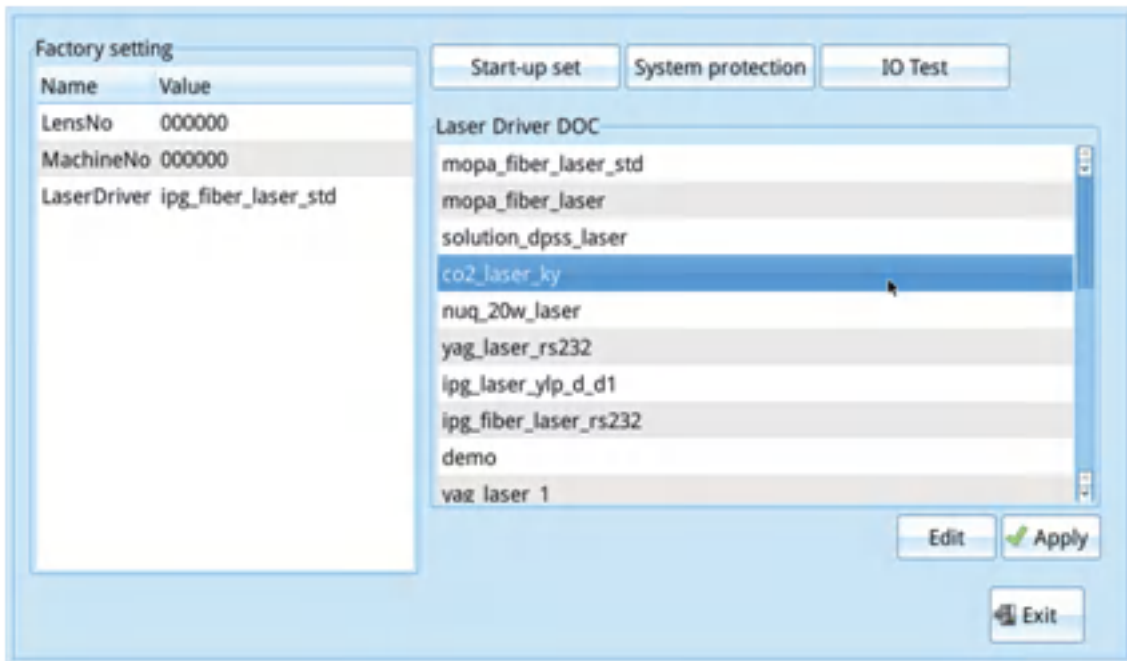

4.3 The Interface Diagram and Software Settings of BSL Control Board

EXT CONTROL

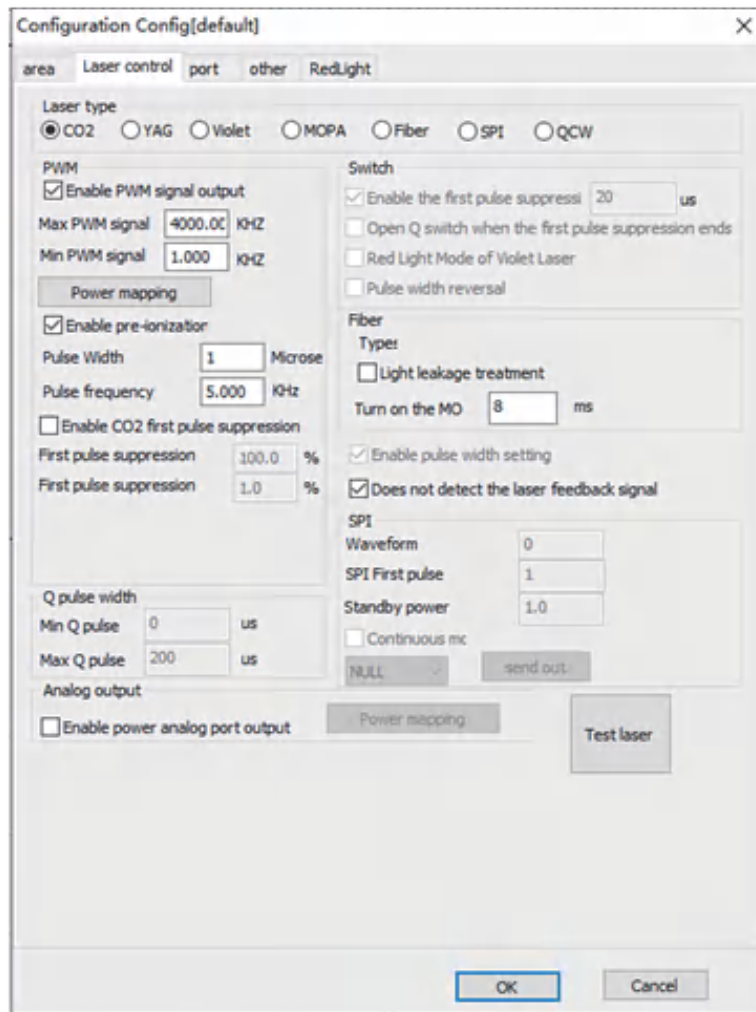
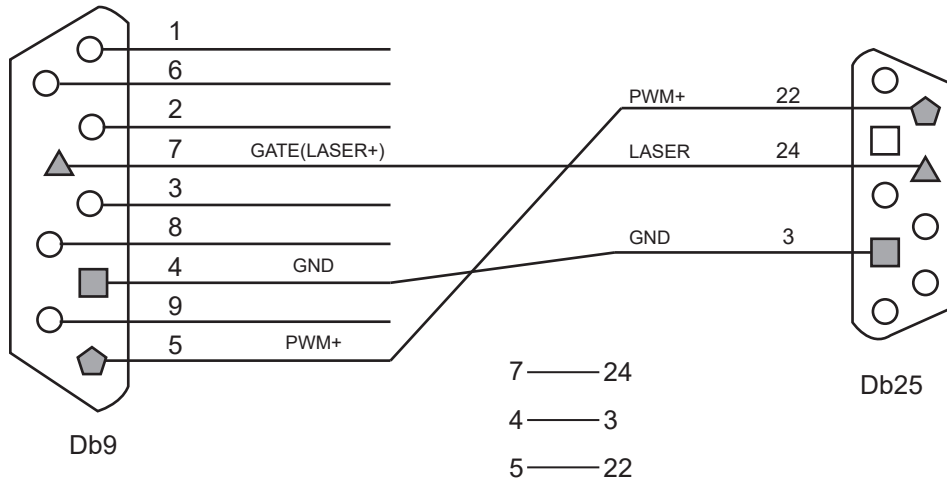

4.4 The Interface Diagram and Software Settings of Earain Control Board

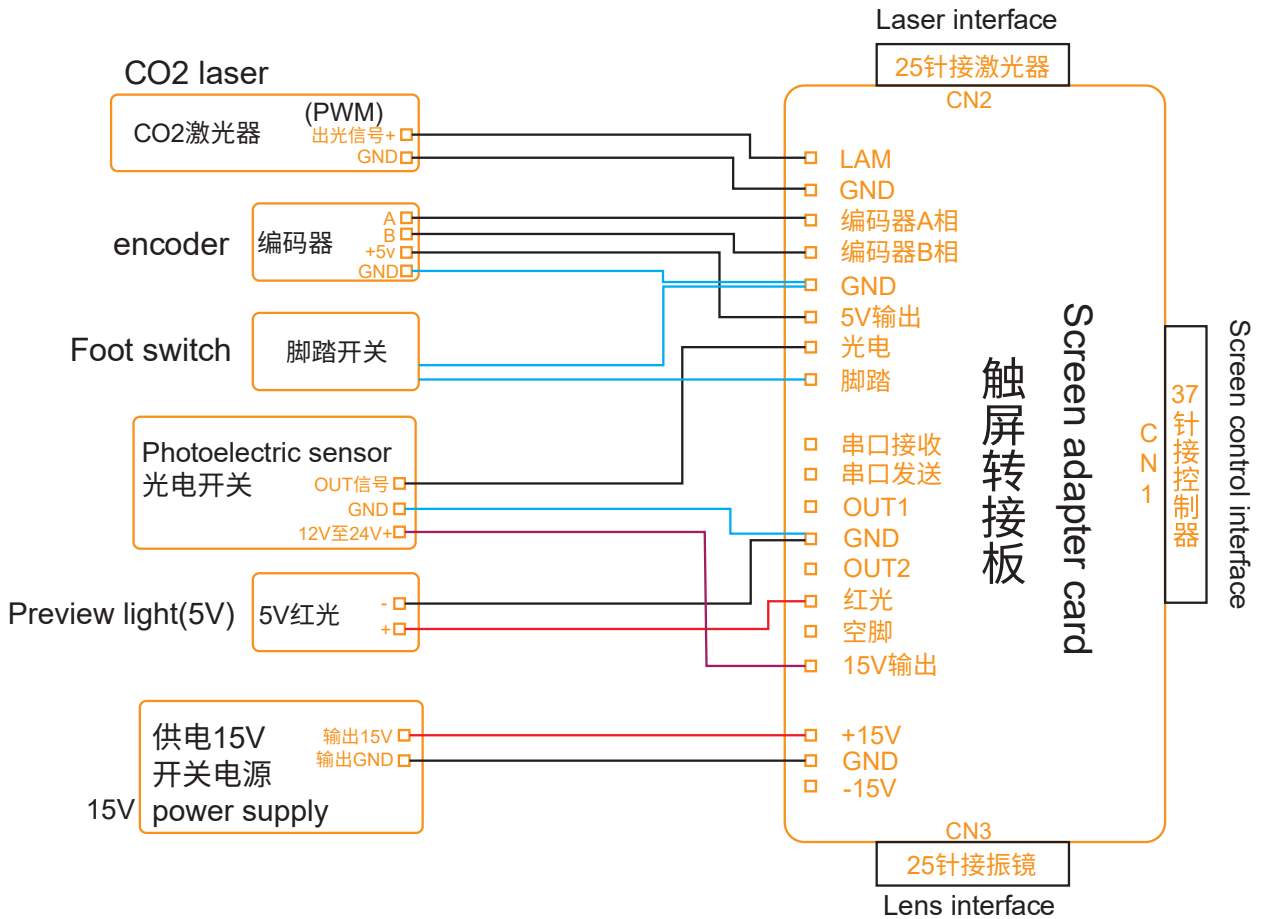



5. Troubleshooting and Maintenance

5.1 What should I do if the laser does not emit laser?

- The power supply is on or off, the red indicator light on the laser should be on after the power supply is on.
- Whether the system has entered the working state or not, if the laser system is ready, the green indicator lights on before the laser can work normally.
 - Check whether the control signal is correct or not; whether a CO₂ control board is used or not, be aware that the fiber control board cannot control the laser; if the control board is confirmed to be correct, please check whether the "PWM+ signal" and "On/Off optical signal" are connected correctly or not. Use a multimeter to check: switch the multimeter to the DC voltage, set the power to "50" on the marking software, and then perform continuous marking. At this time, the PWM+ signal should have a voltage output of about 2.5V, and the "On/Off optical signal" voltage should be 5V, and then set the power further to "90" to continuously mark. At this time, the PWM+ signal should have a voltage output of about 4.2V, and the "On/Off optical signal" voltage should be still 5V, which means the signal is normal. If an oscilloscope is available, it is more accurate to use an oscilloscope to do the check.
 - Check whether the terminals of the signal cable are soldered correctly or not. The 4-pin of the laser to be connected to the GND of the control board; the 5-pin to connected to the PWM+ signal of the control board, and the 7-pin connected to the On/Off optical signal of the control board.
 - Check whether the plug of signal cable is firm or not.

5.2 The laser intensity becomes weak after working for a period of time?

- Check whether the air duct is blocked
- Whether the working temperature is normal or not.
- Whether the field lens and galvanometer are polluted or not.

6. After sale service

6.1 Warranty

All laser source products from Tianjin Maiman Laser Technology Co., Ltd. come with an 18-month warranty period, which certifies that your laser is found to be free of any defects in material or workmanship. This warranty applies regardless of your laser application. It does not cover any issues that may arise due to operator negligence, environmental factors, accident, alterations, or improper maintenance. Tianjin Maiman Laser Technology Co., Ltd maintains the sole authority to make any claims or statements regarding warranty on its products. Maiman Laser reserves the right to make changes or improvements to product design without notice, and without expectation of equivalent changes in products previously manufactured or shipped.

6.2 Returns

If a failure should occur, please contact maimanlaser@maimanlaser.com or +86 17526524352. If a laser or accessories needs to be returned, a Return Merchandise Authorization(RMA) will be issued. Any laser returned without an RMA will be at your sole expense.

Typically, for failure within the 18 months, the client shall be responsible for shipping costs to Tianjin Maiman Laser Technology Co., Ltd. or its distributors. Maiman Laser or its distributors will pay all shipping costs to return the item(s) to the client.

When requesting an RMA please have the following information ready:

Date of purchase:

Date of receiving the laser:

Laser Model:

Date the issue was first discovered:

Brief description of the issue:

Find out the RMA as completely as possible. For any returns, please ship the item(s) to:

Tianjin Maiman Laser Technology Co., Ltd.

Attn: Overseas Department, Lynn Zhang

201, D6-A, East Huigu Industrial Park, Xiqing District, Tianjin, China

Include the laser and all accessories when returning the laser. This allows Maiman Laser to determine the source of the issue.

Tianjin Maiman Laser Technology Co., Ltd.

Address: 201, D6-A, East Huigu Industrial Park, Xiqing District, Tianjin

Tel: +86-22-8789 4207 8789 4217

Mobile: +86-22 175 2652 4352

Fax: +86-228789 4217

Web: www.maimanlaser.com

E-mail: maimanlaser@maimanlaser.com



[View website](#)



[View catalog](#)



WhatsApp

Tianjin Maimanlaser Technology Co., Ltd. reserves the copy right of this catlog and reserves all the rights to change the information and specifications contained in this catlog without prior notice.

Version updated on April 16th, 2024.