

Maiman

Superb Technology & Optimum Quality

Diamond series

high energy 70ns laser

Instruction manual

VN: HSL20240429

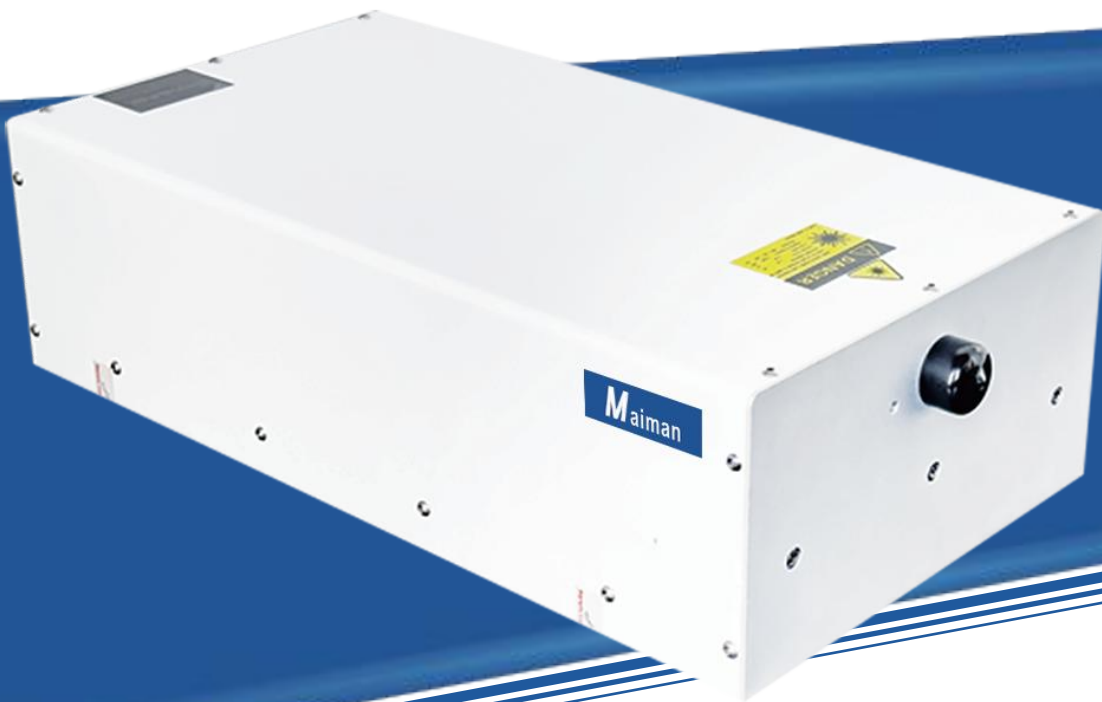

Tianjin Maiman Laser Technology Co., Ltd.

Preface

This manual is applicable to engineers who have basic knowledge of hardware and have a certain understanding of laser equipment and device. Please read through this manual carefully before using the Maiman laser products and keep it properly. If you have any questions, please contact Tianjin Maiman Laser Technology Co., Ltd.

For more product and information, please visit our website
www.maimanlaser.com



Content

1. Maiman Laser Safety Instructions	01
1.1 Declaration of Safe Use	01
1.2 Safety and Warning Signs	01
1.3 Guidelines for Safety Operation of the Laser	02
1.4 Product Safety Features	03
2. Product Installation Instructions	04
2.1 Laser Installation and Service Conditions	04
2.2 Supplied Accessories	05
2.3 Description of Laser Interface	06
2.4 Installation Instructions	08
2.4.1 Installation Method of Laser	08
2.5 Dimensional Drawing	09
2.6 Instruction of RS232 Control Mode	10
2.6.1 Software Installation	10
2.6.2 Software User Guide or Software Usage Instructions	10
2.7 MMSIO2PV-1 Interface Board Protocol Instruction	13
2.7.1 Overview	13
2.7.2 Command introduction	13
3. Laser Operation Instructions	15
3.1 Startup Process	15
3.2 Shutdown Process	16
4. Connection with Common Systems and Software Settings	17
4.1 The Interface Diagram and Software Settings of EzCad Control Board	17
4.2 The Interface Diagram and Software Settings of Central-laser Control Board	19
4.3 The Interface Diagram and Software Settings of BSL Control Board	21
4.4 The Interface Diagram and Software Settings of Earain Control Board	22
5. Troubleshooting and Maintenance	23
5.1 What should I do if the laser does not emit laser	23
5.2 The laser intensity becomes weak after working for a period of time	23
6. After sale service	24
6.1 Warranty	24
6.2 Returns	24

1. Maiman Laser Safety Instructions

1.1 Declaration of Safe Use

The manual must be read through carefully before using the Maiman laser, and operators must operate in strict accordance with the guidelines of the manual, so as to avoid the damage to the human body and property caused by improper operation. If the operator does not use the product in accordance with the guidelines of the manual, Tianjin Maiman Laser Technology Co., Ltd. will not bear any legal responsibility for all personal and property damages arising therefrom.

1.2 Safety and Warning Signs/Labels

	<p>Laser radiation warning sign Viewing visible or invisible laser light emanating from the laser will cause serious injury and potential blindness, as is reflected, scattered, and diffuse light.</p>
	<p>Safety Warning sign The specific procedures need to be followed, otherwise your device or parts may be damaged or will bring danger. You need to follow specific procedures, otherwise your equipment or components may be damaged or dangerous.</p>
	<p>The production label</p>
	<p>Anti disassembly label I . No warranty if the label is damaged.</p>
	<p>Anti disassembly label II .No warranty if the label is damaged.</p>
	<p>Maiman's logo</p>
	<p>QR code</p>



1.3 Guidelines for Safety Operation of the Laser

- The laser products of our company belongs to class IV laser device ($>500\text{mw}$) according to its output power level, The laser radiation will cause serious harm to human body, as well as fire and other hazards. Only qualified personnel who have been trained and are well aware of the danger of laser are allowed to operate this product. Non operators should evacuate outside the danger area of laser radiation.
- After long-distance transportation, the machine must be allowed to sit idle for half an hour before powering on. This waiting period is necessary to allow the laser to reach a stable ambient temperature and avoid power discrepancies caused by temperature variations within the cavity. Only after this waiting period should the power supply be switched on.
- Do not open the casing of the laser body under any circumstances.
- Establish a safe operation area around the laser and take necessary measures to prevent the leakage of the laser. Post Class IV laser warning signs and safety warning signs at obvious positions in the safe operation area to prevent untrained personnel from entering.
- Store the laser in a place with certain power protection conditions, and all parts of the laser should have good grounding protection.
- Wear professional laser protective glasses, gloves, protective clothing, etc. during operation. Do not look at the laser beam directly without protective measures, do not touch the laser beam directly to avoid damage to eyes, skin, clothing, etc.
- Do not wear jewelry or any reflective objects, and do not irradiate the light beam on the reflective surface, so as to avoid personal injury caused by the reflected light.
- Take measures to block the reflected beam, or use a working platform with CLASS IV protection grade when processing metal parts which may reflect beam strongly.
- Keep the laser beam above or below the human eyes during operation, do not keep it on the same level as the human eyes.
- If volatile substances are used in the laser operation area, cleaned them out of the operation area immediately after the operation.
- After operation, the operator should check with the fluorescent sheet to confirm that the laser has been turned off before leaving.
- The maintenance and repair of the device should be carried out by professionally trained personnel. Be sure to refer to the relevant contents in the manual.



1.4 Product Safety Features

- Power indicator light: Red - When the indicator lights up, it means the laser is powered on, but cannot judge whether the laser is on or off. Take great care at all times when using the laser. When the indicator light is off, it means that the laser is not powered on. At this time, the laser is in the off state.
- Work indicator light: Green - When the indicator lights up, it means that the laser can work normally, but cannot judge whether the laser is on or off. Take great care at all times when using the laser. When the indicator light is off, it means that the laser is not ready. At this time, the laser is in the off state.

2. Product Installation Instructions

2.1 Laser Installation and Service Conditions

- Do not power on the laser during installation and disassembly, otherwise the laser will be burned; at the same time, pay attention to anti-static to avoid electrostatic breakdown of the internal laser diode;
- The working temperature of the laser is $25\text{ }^{\circ}\text{C} \pm 1\text{ }^{\circ}\text{C}$, and too high or too low temperature will weaken the laser power;
- The laser power supply is a special switching power supply. Use the laser's own switching power supply. Do not replace it without permission. Connect the laser power supply cable correctly, otherwise the laser will be burned directly;

Note: Beam expanders and window mirrors are not covered by the warranty;

- Pay attention to the cleanliness of the chiller. Pollution is likely to block the internal waterway of the laser and affect the normal working of the laser. Please use antifreeze below 0°C to prevent freezing. The freezing of cold water will deform the laser and cause power attenuation;
- Laser damage caused by human factors is not within the scope of warranty;
- No warranty if the anti disassembly label is damaged.

Category	Item	Specification
Electrical requirements	Switching power supply input voltage	AC100-240V, 50-60Hz
	Switching power supply output voltage/current	DC24V , 25A
	Laser input voltage/current	DC24V , 25A
	Running power	500W
Environmental requirements	Storage temperature	-10-40°C
	Storage humidity	<90%(No condensation)
	Operating temperature	10-35°C
	Operating humidity	<80%(No condensation)
	Dust	< 0.20mg/m ³
	Oil mist	Non
	Electromagnetic environment	GB Class II
Chiller requirements	Shock	Isolate vibration sources
	Cooling power	$\geq 1\text{kW}$
	Set temperature	25°C
	Refrigeration temperature fluctuation	$\pm 0.1^{\circ}\text{C}$
	Water flow	10L/min@0.18MPa
	Pump head	20m

Remark: •The coolant of the chiller should be pure water, distilled water or deionized water. Do not use daily drinking water or mineral water. Otherwise, the water channel will be easily blocked and the laser will be damaged.

2.2 Supplied Accessories

No.	Item	Picture	Qty	Unit	Description
1	High energy 70ns laser		1	set	16W/18W/20W /25W
2	Switching power supply		1	piece	LRS-500-24
3	Power supply cable		1	piece	3*2.5, 2m
4	Fixed foot		4-5	piece	M4
5	9-pin plug		1	set	DB9 pin
6	9-pin housing		1	set	DB9pin shell
7	Screw of fixing feet		8-10	piece	M4*10
8	RS232 Serial Cable		1	piece	1.8m
9	RS232 Passive Serial Optical Isolator		1	piece	DB9
10	Filter		8	piece	DB9
11	Detection Form		1	piece	—

Remark: ●The photos are for reference only, and the real object shall prevail.

2.3 Description of Laser Interface

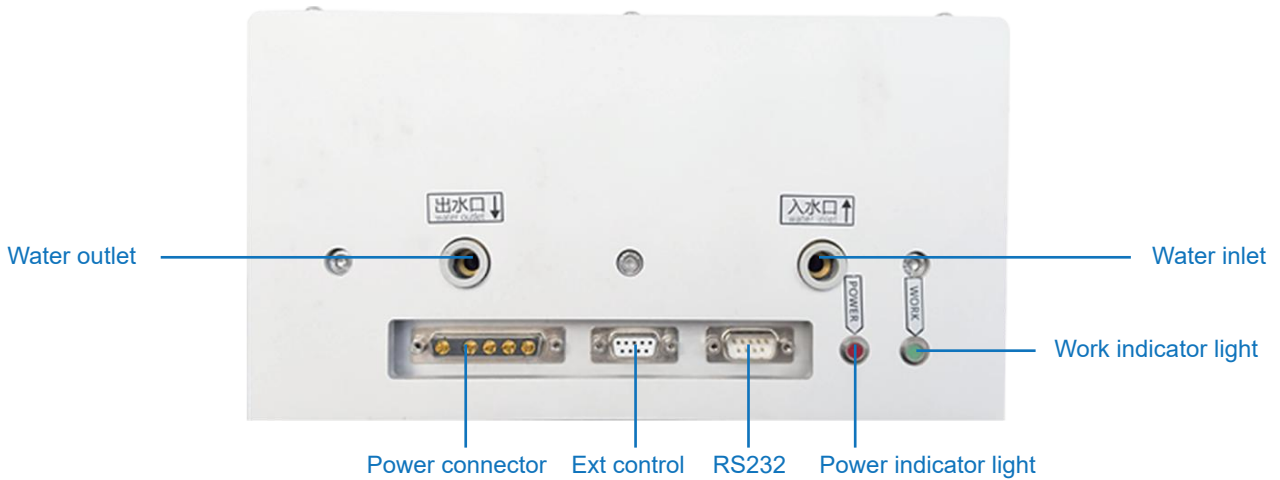

- **Power connector**

Provides DC constant voltage power supply for the laser. The laser is powered by the attached power supply cable and AC-DC switching power supply. Pay attention not to short circuit or connect incorrectly during wiring, otherwise the laser will be burned directly;

- **Cooling water interface (water inlet and water outlet)**

Provide cooling for the laser. Use a pneumatic tube or a hard water tube with an outer diameter of 10mm to connect the "water outlet" of the chiller to the "water inlet" of the laser, and the "water inlet" of the chiller to the "water outlet" of the laser. Connect the joint tightly to ensure no water leakage. When replacing the water tube, first press the edge of the water tube joint to make the joint completely flat, and then pull out the water tube. Do not pull it out directly, which will cause water leakage of the joint.

- **Ext control**

Control laser output and parameter adjustment. It is the external control interface (pin DB9), which is connected with the control board and the water pressure protection signal of the chiller, as defined below:

No.	Item	Description
Pin 1	Water pressure protection line of chiller	
Pin 2	Water pressure protection line of chiller	
Pin 3	NC (vacant, not connected)	
Pin 4	GND	
Pin 5	PWM+	Frequency control for laser
Pin 6	NC (vacant, not connected)	
Pin 7	LASER or GATE signal	On/Off optical signal, must be connected, otherwise it will not work properly
Pin 8	NC (vacant, not connected)	
Pin 9	NC (vacant, not connected)	



Laser output and beam expander interface

- **Power indicator light**

Red - When the indicator lights up, it means the laser is powered on, but cannot judge whether the laser is on or off. Take great care at all times when using the laser. When the indicator light is off, it means that the laser is not powered on. At this time, the laser is in the off state.

- **Work indicator light**

Green - When the indicator lights up, it means that the laser can work normally, but cannot judge whether the laser is on or off. Take great care at all times when using the laser. When the indicator light is off, it means that the laser is not ready. At this time, the laser is in the off state.

- **Laser output and beam expander interface**

Laser output port, there is a green protective lens can be replaced if necessary, note that the replacement of protective lenses need to be in a clean environment, no flow of air, to prevent contamination of the internal window piece of the laser.

2.4 Installation Instructions

2.4.1 Installation Method of Laser

Installation process

- Install the fixed feet outward to the bottom of the laser;
- Install the laser on the laser equipment.

Remark: the mounting surface should be flat to ensure that the laser fixed feet fully fit the surface.



Fixed feet, Screws, The laser ▲



Bottom view of the laser after the fixed feet are installed ▲



Install the fixed feet on to the laser ▲

2.5 Dimensional Drawing

Top view

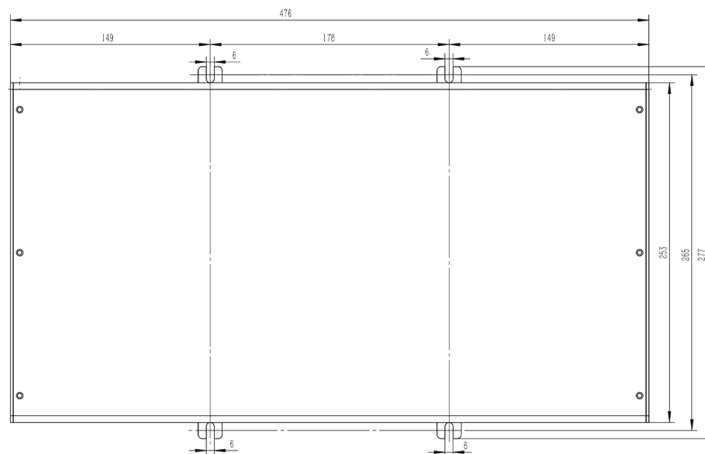

Front view

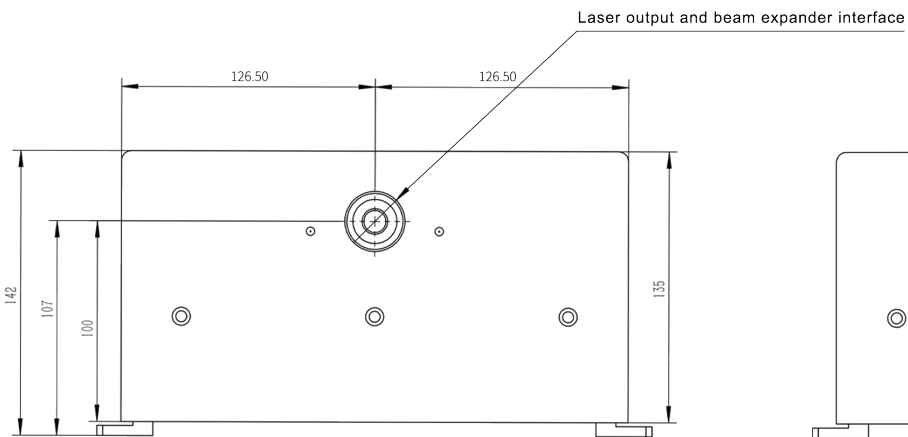

Rear view

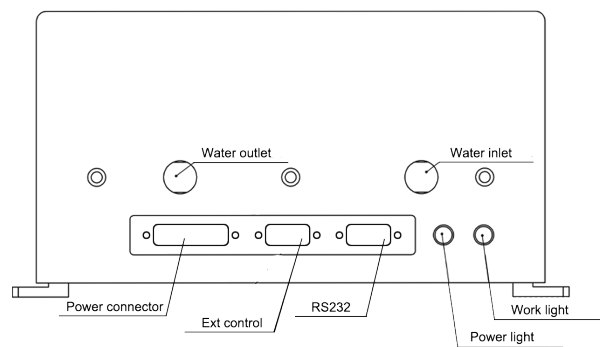

2.6 Instruction of RS232 Control Mode

2.6.1 Software installation

(1) Double-click  Maiman_LCS_V1.2.0 in the software package to install the software. The software is provided by Maiman. During the installation process, the anti-virus software needs to be stopped, otherwise the installation may fail;

(2) Install the RS232 driver, which is provided by the supplier of the RS232 data cable. The RS232 data cable connected to the Maiman laser is a USB to RS232 serial port 9-pin female;

2.6.2 Software instructions

(1) After the software is installed, click the shortcut  to enter the software interface, as shown in the picture below:

software interface:

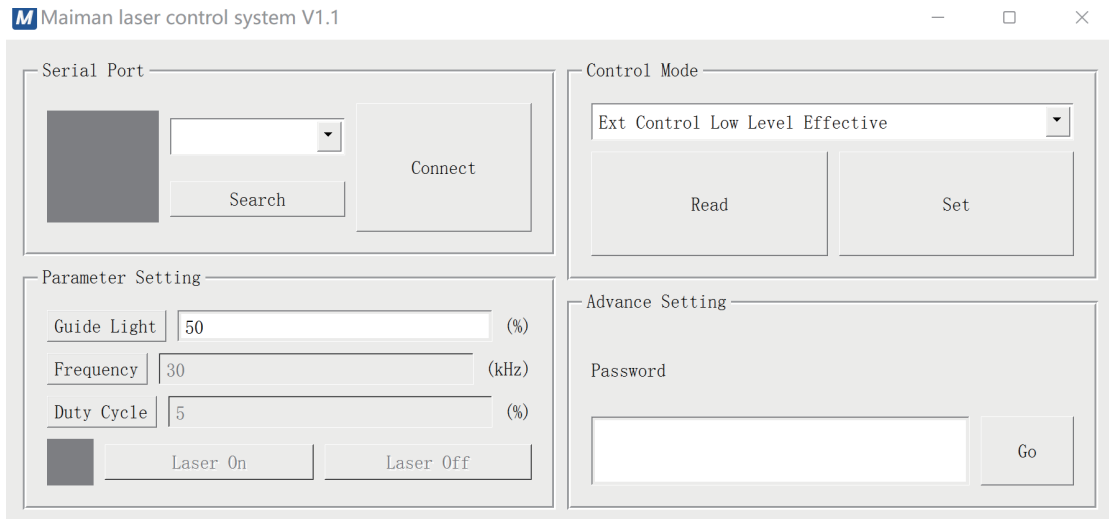

Software interface function description:

Search	Search for COM port
Connect/disconnect	Software Connect/Disconnect with COM Port
Guide light	Adjustment of Indicator Light Intensity
Frequency	Laser Frequency Setting (PWM Signal Frequency)
Duty cycle	Laser Power Setting (PWM Signal Duty Cycle)
Laser on	Laser Output (For Int Control Mode Only)
Laser off	Laser Shutdown (For Int Control Mode Only)
Control mode	Laser Control Mode Selection
Read	Read Last Power-Off Parameters (Rarely Used)
Set	Configuration (Changes take effect after completion of settings)



(2) Connect the RS232 data cable, click the "Search" button on the software interface, you will find the corresponding "Com port", and then click the "Connect" button to connect, and the square on the left will turn green after the connection is complete;

(3) Set the laser parameters, among which "Guide Light" can adjust the intensity of the UV/Green indicator light by inputting a percentage; "Frequency" and "Duty Cycle" are options for adjusting of laser frequency and Q switch duty cycle, these two adjustment options can only be applied in the internal control mode.

The frequency and duty cycle of the external control mode are determined by the external signal;

(4) "Control Mode" is for the selection of different control modes. There are 5 control modes available in the drop-down menu:

4.1) Ext Control Low Level Effective (external control low level effective)

At this mode, the frequency and power of the laser are all determined by the external signal. At this time, the greater the duty cycle of the signal, the greater the output power of the laser, and the laser has continuous indicator light output when there is no external signal input. Under this option, only the "Guide Light" option can be adjusted to adjust the intensity of indicator light;

4.2) Ext Control High Level Effective (external control high level effective)

At this mode, the frequency and power of the laser are all determined by the external signal. At this time, the smaller the duty cycle of the signal, the greater the output power of the laser, and when there is no external signal input, the laser has no continuous indicator light output;

4.3) Ext Trigger Int Control Low Level Effective (External trigger internal control low level effective)

At this mode, the frequency and power of the laser are all set by "Frequency" and "Duty". At this time, the greater the duty cycle of the signal, the greater the output power of the laser. And when there is no external signal input, the laser has a continuous indicator light output. The laser output needs to give a 7 pin TTL trigger signal to the external control port 7, which is effective at high level;

4.4) Ext Trigger Int Control High Level Effective (External trigger internal control high level effective)



At this mode, the frequency and power of the laser are all set by "Frequency" and "Duty", at this time the smaller the duty cycle of the signal, the greater the output power of the laser, and when there is no external signal input, the laser does not have a continuous indicator light output. The laser output needs to give 7 pin TTL trigger signal to the external control port, which is effective at high level;

4.5) Int Control (internal control mode)

At this mode, the frequency and power of the laser are all set by "Frequency" and "Duty", at this time the smaller the duty cycle of the signal, the greater the output power of the laser, and when there is no external signal input, the laser has no continuous indicator light output. Click the "Laser on" button to emit laser according to the set parameters, and click the "Laser off" button to stop the laser output.

(5) The laser has a minimum frequency setting. When the frequency setting lower than 30kHz, the laser is in protection state and no laser output;

(6) The software has a memory function. The last parameters setting will remain unchanged the next time it is turned on.

(7) The laser can also run without installing the software. "Ext Control High Level Effective" for 8Watt and above power models. At this time, only external control signal needed, no need to install software and connect data lines;

(8) "Advance setting" option is the engineering interface, and it does not require customer operation.

(9) The software has a timed lock function. The default period of use is permanent when leaving the factory. If you want to use the lock function, please contact Maiman Laser.



2.7 MMSIO2PV-1 Interface Board Protocol Instruction

2.7.1 Overview

The MMSIO2PV-1 laser interface board is a conversion board with multi-mode and configurable parameters. This instruction mainly introduces the definition of the communication protocol between the interface board and the host computer or other controllers through the RS232 interface.

2.7.2 Command introduction

The parameters of the RS232 serial port are 9600,8,N,1.

There are two types of commands. The first type is to query related parameters, and the second is to set related parameters.

This instruction defines the interface board as the slave device and the host computer as the host device.

All commands end with `\r\n`

(1) Query commands:

1) Host send : `mode?\r\n` To inquire all current parameters

Slave response : `check_mode:1\r\n`

`check_power: 10\r\n`

`check_freq: 20\r\n`

`check_duty: 30\r\n`

`check_max_freq: 200\r\n`

`check_min_freq: 20\r\n`

Notice: There are 5 modes in total-

0: Ext Contral Low Level Effective

1: Ext Contral High Level Effective

2: Ext Trigger Int Control Low Level Effective

3: Ext Trigger Int Control High Level Effective

4: Int Control

2) Host send : `check_freq?\r\n` To inquire the current input frequency

Slave response : `Input freq:5000 Hz\r\n`

(1) Setting commands:

1) Host send : `set_mode:3\r\n` To set the current mode, 0-4

Slave response : `set mode:3\r\n`



- 2) Host send : set_power:50\r\n To set the power value, 0-100
Slave response : set power:50\r\n
- 3) Host send : set_freq:80\r\n To set the frequency value, min freq-max freq, unit kHz
Slave response : set freq:80\r\n
- 4) Host send : set_duty:35\r\n To set the duty cycle, 0-100
Slave response : set duty:35\r\n
- 5) Host send : laser_on\r\n To turn on frequency output, only valid at Int Control mode
Slave response : laser_on_ack\r\n
- 6) Host send : laser_off\r\n To turn off frequency output, only valid at Int Control mode
Slave response : laser_off_ack\r\n

3. Laser Operation Instructions

3.1 Startup Process

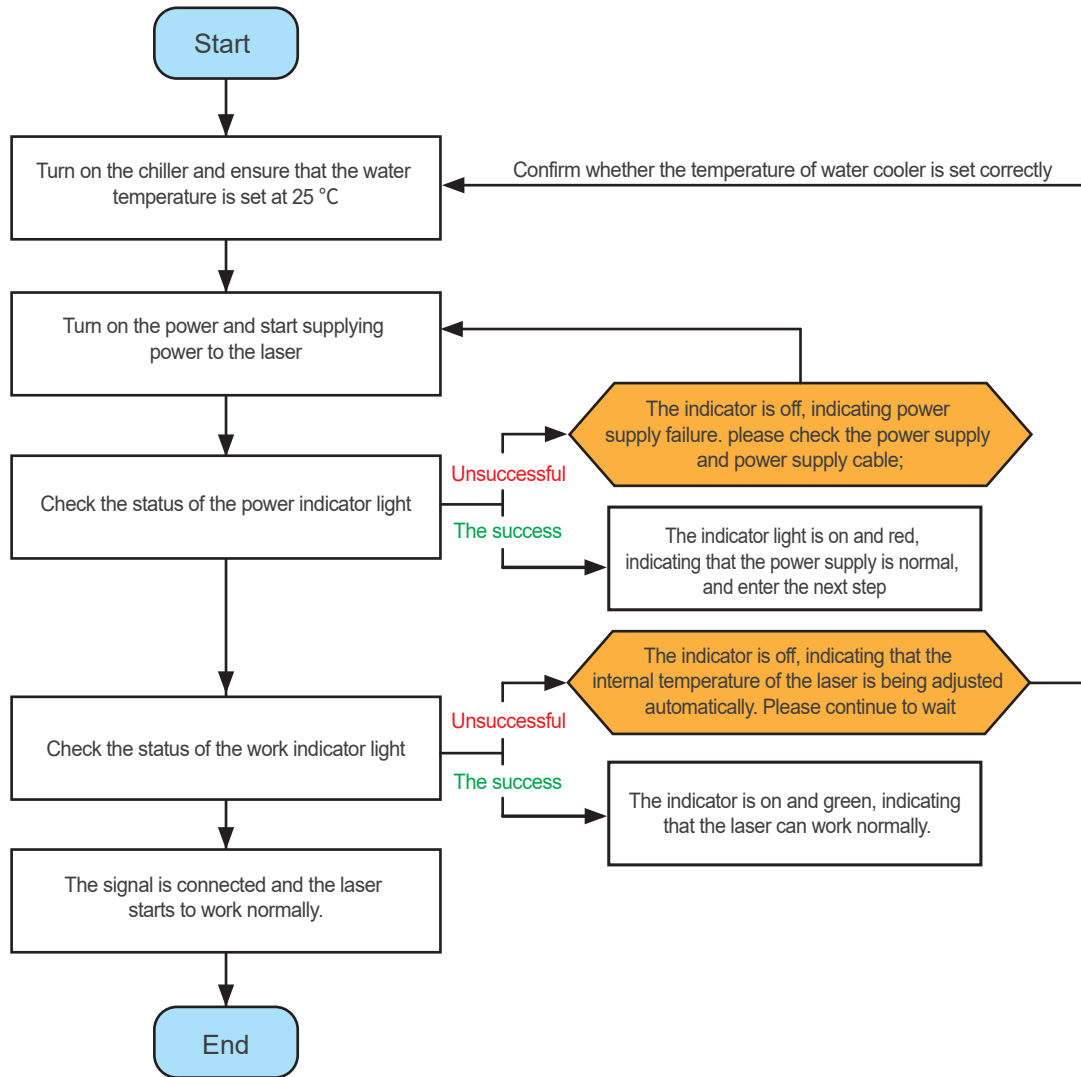

⚠ Notice:

- Check the external environment before starting the laser, and make sure that the power, cooling water and protection system are all normal before running the laser device.
- Before starting, Check and make sure that all interfaces are installed correctly without looseness. When the laser is working, do not unplug the connection between the switching power supply and the laser, otherwise the laser will be burned directly. If the cable is found to be loose or not connected, please turn off the power first, and then fasten or connect it.
- It takes 5 minutes to start up the device. After the power is turned on, the red indicator light on, which means the laser power supply is normal at this time; the green indicator light on, which means that the laser system is ready and can work normally.

3.2 Shutdown Process

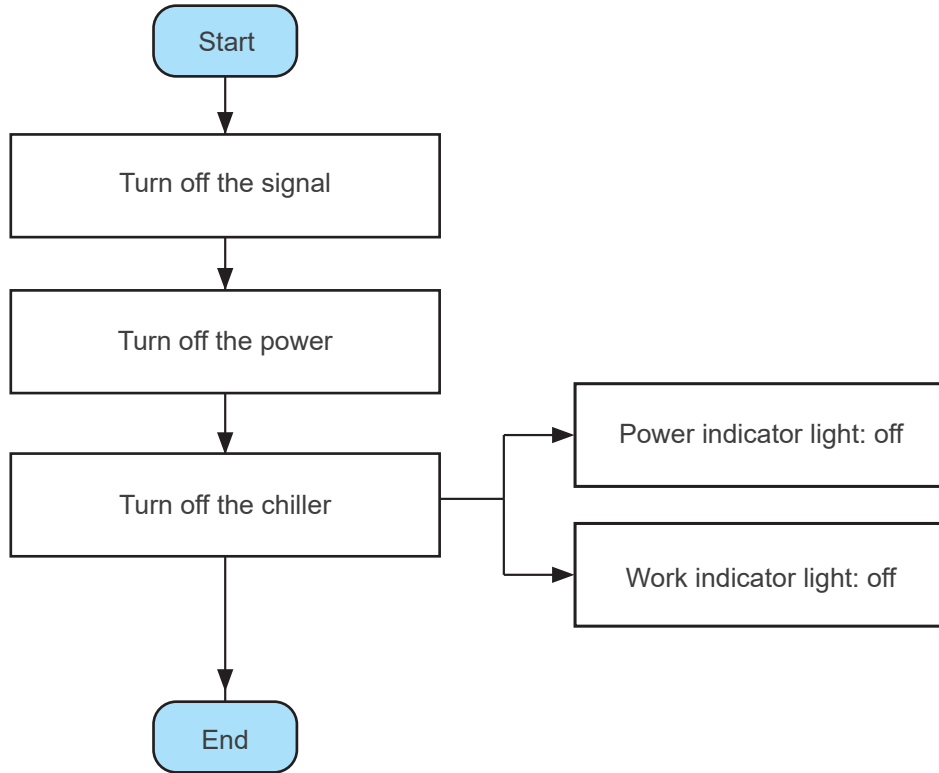

⚠ Note:

- Do not turn off the chiller before turning off the power; turning off the chiller first may cause the device to burn out.

4. Connection with Common Systems and Software Settings

The connection and software settings with the control systems of EzCad, Central-laser, BSL, and Earain are listed below, and laser control can be realized according to this operation. Please contact the companies directly for more details of control system.

- ☆ CO2 control mode and YAG control mode are optional
- ☆ CO2 control mode is recommended, which is simpler and easier to understand.
- ☆ The wiring of the two control modes are exactly the same.

4.1 The Interface Diagram and Software Settings of EzCad Control Board

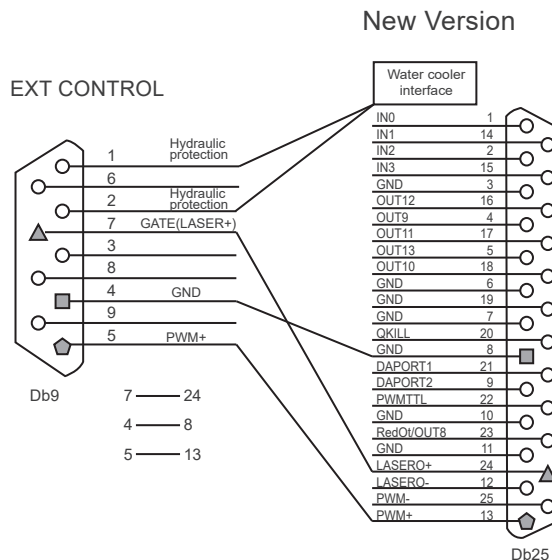
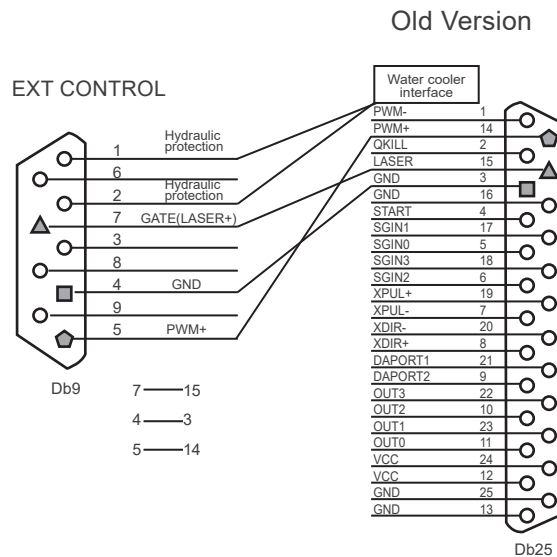

EzCad Control Board setting example:

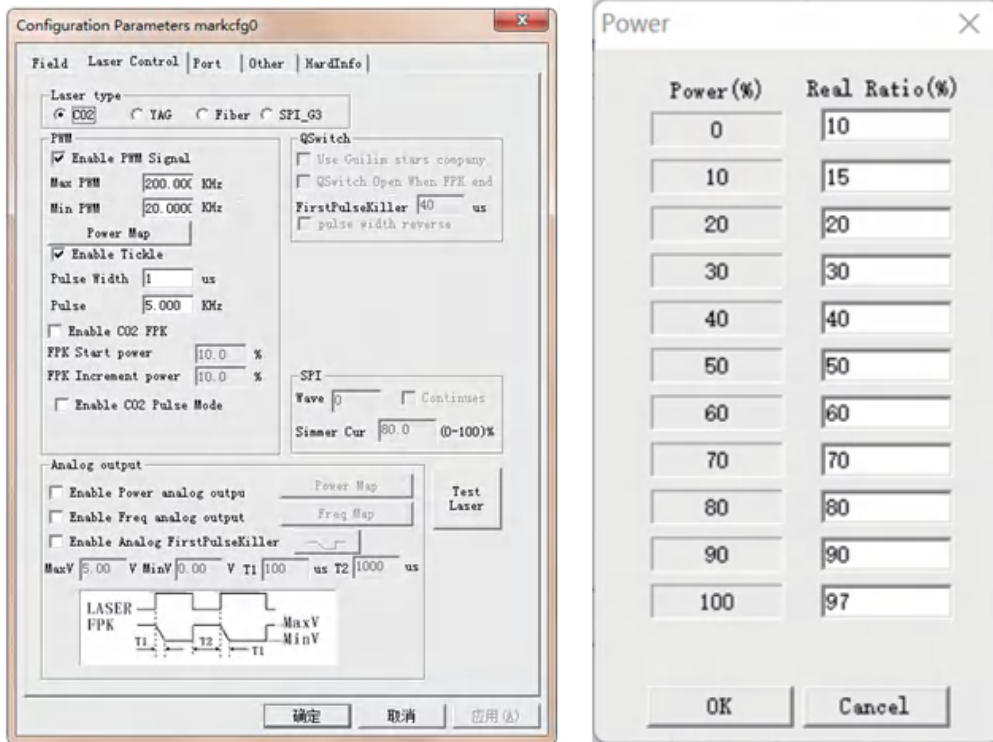

★ Note: The laser can be controlled by CO2 mode. Take the EzCad Control Board as an example, the settings are as shown in the picture above, select the CO2 control mode, and then click the "Power Map" button to set as shown in the picture above, so the maximum Real Ratio(%) is 97. Do not check the "Enable Tickle" option, otherwise it will cause laser leakage.

⚠ Warning: If you purchase a laser controlled by CO2 mode, please use a CO2 control board to cooperate with it!

4.2 The Interface Diagram and Software Settings of Central-laser Control Board

Markingmate series UMC4 control board

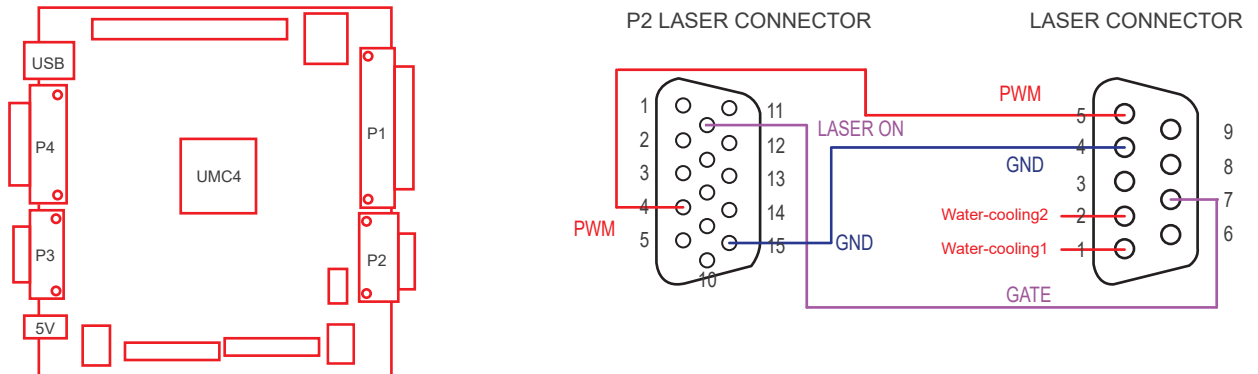

Drive selection: Select CO2 mode for Maiman UV laser drive

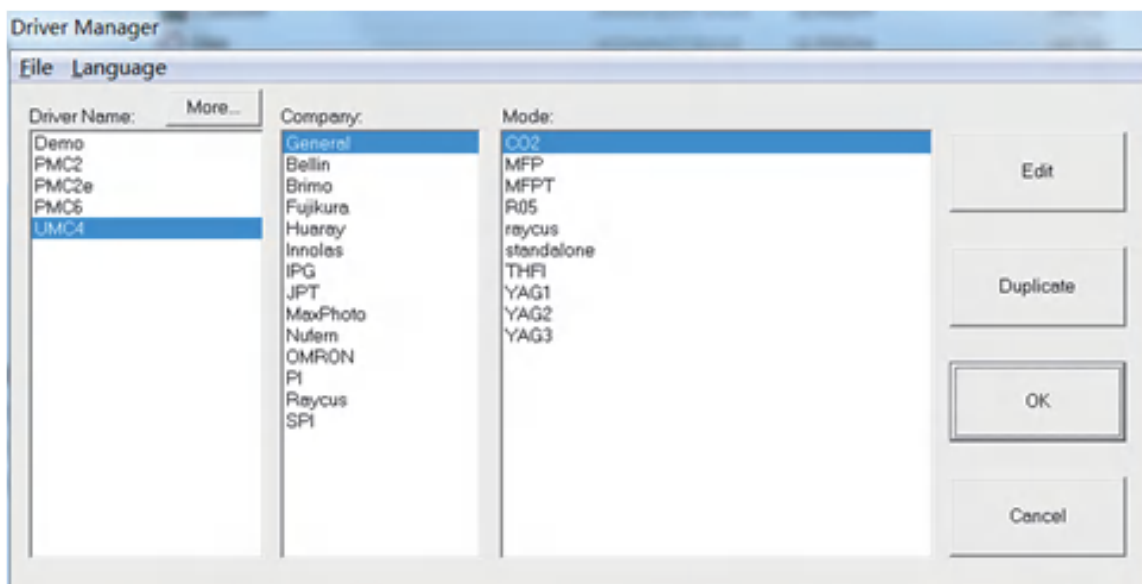

NMC Touch Screen Flying Series MC3 Control Board Wiring:

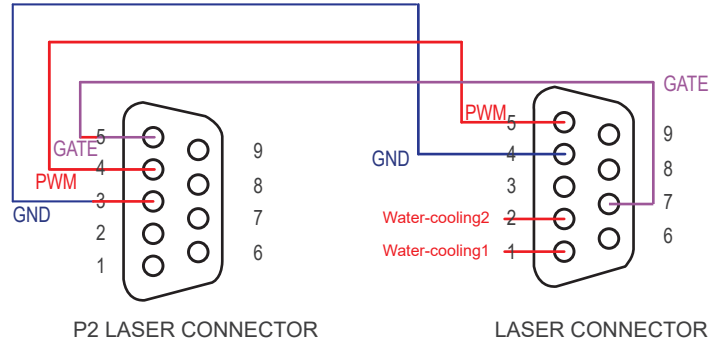
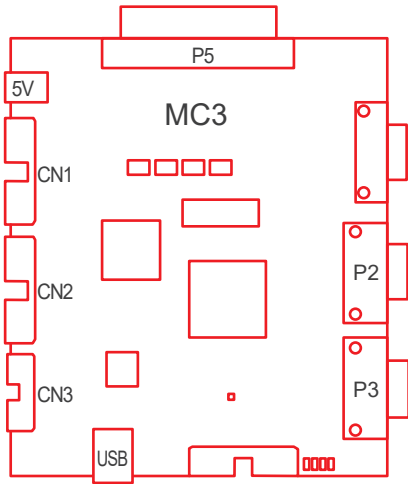

Drive selection: Select CO2-laser-Ky for Maiman UV laser drive

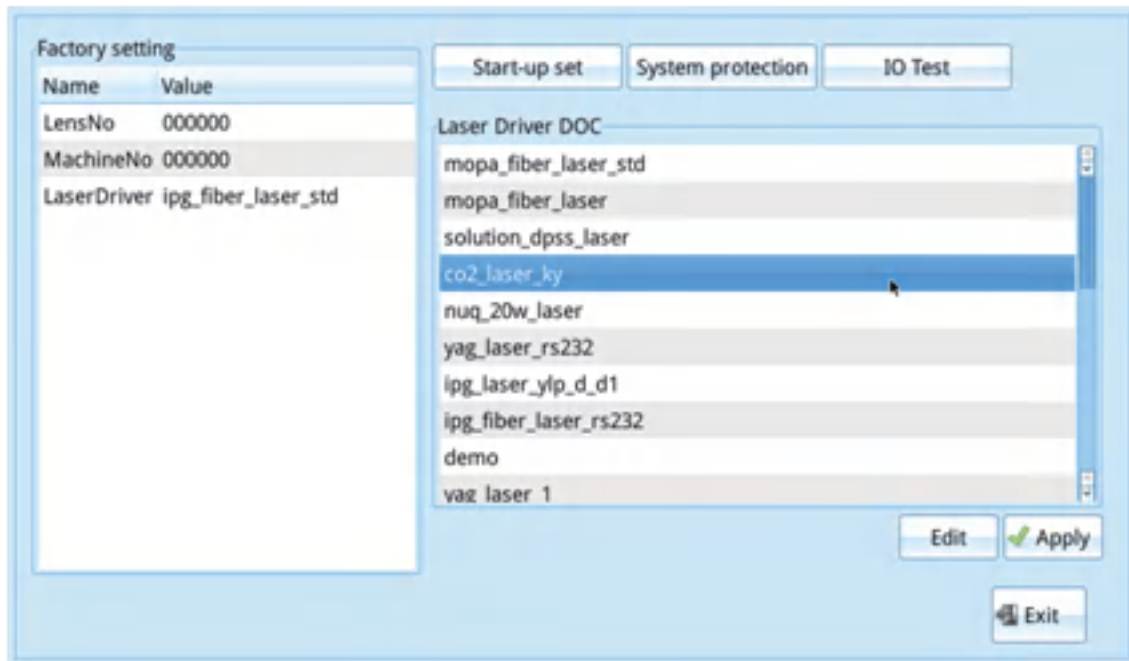

4.3 The Interface Diagram and Software Settings of BSL Control Board

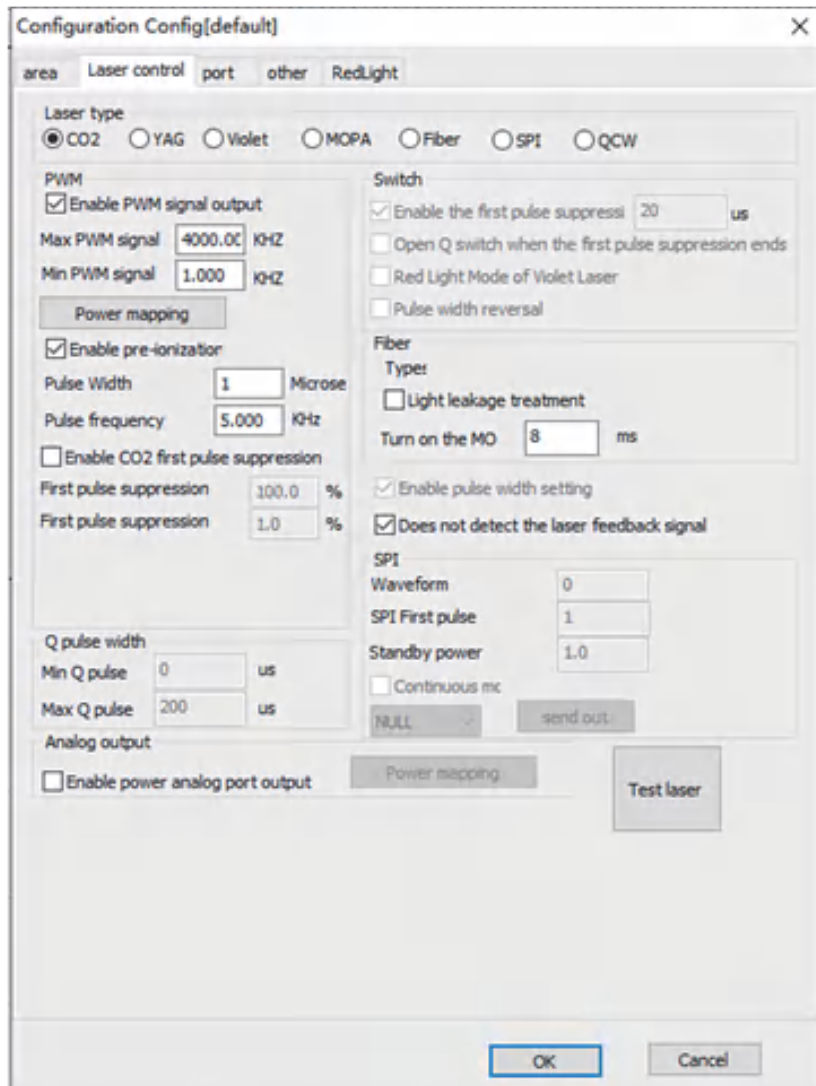
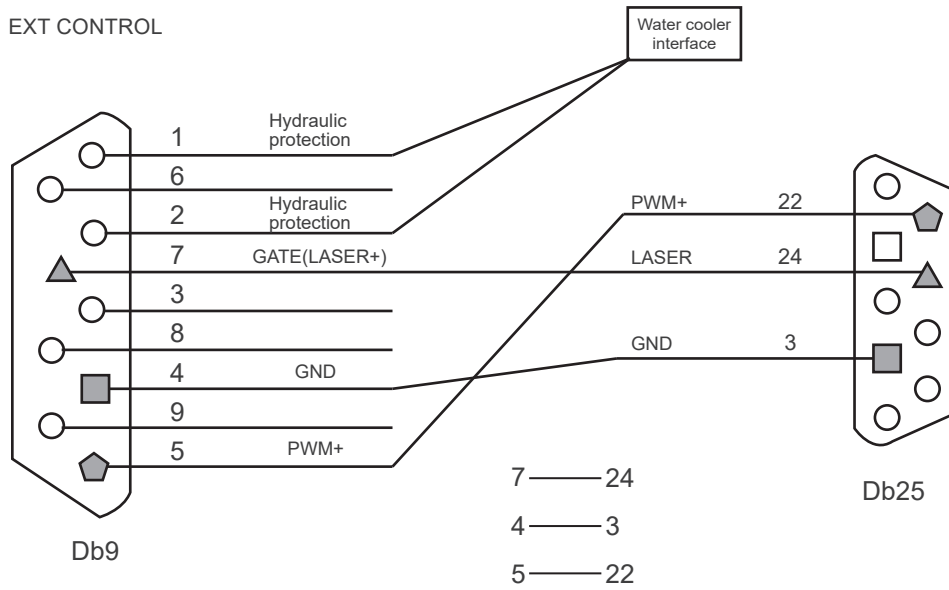

4.4 The Interface Diagram and Software Settings of Earain Control Board

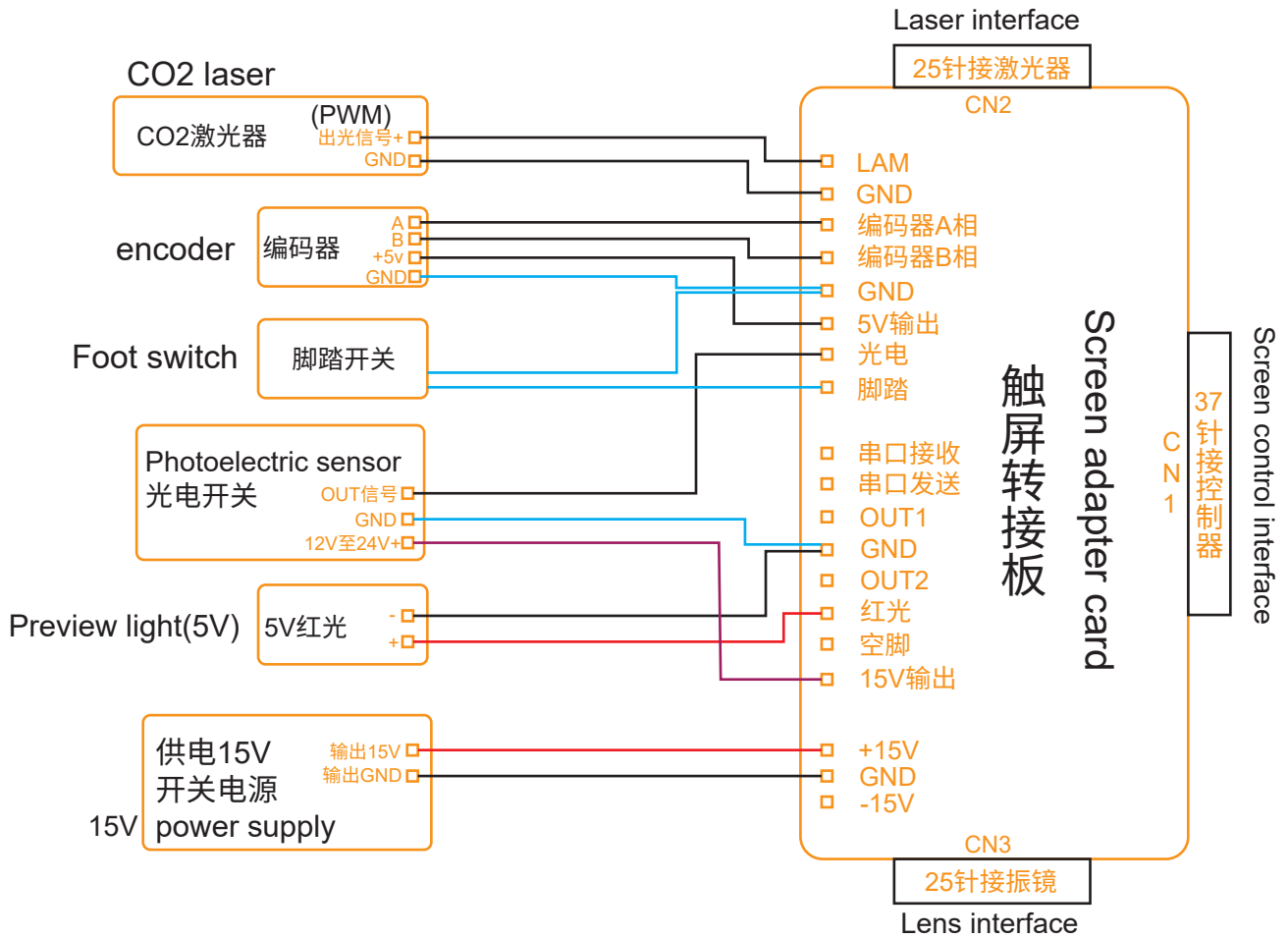



5. Troubleshooting and Maintenance

5.1 What should I do if the laser does not emit laser?

- Check whether the chiller is running or not and whether the set temperature is correct or not.
- Check whether the water pressure protection cable is connected or not. After the chiller starts up, the water pressure protection cable should be in a short-circuit state. Users can measure whether the water pressure signal line is normal or not with a multimeter.
 - The cooling power of the chiller is too small to keep the laser at 25°C, and the temperature fluctuates greatly.
 - The power supply is on or off, the red indicator light on the laser should be on after the power supply is on.
 - Whether the system has entered the working state or not, if the laser system is ready, the green indicator lights on before the laser can work normally.
- Check whether the control signal is correct or not; whether a CO₂ control board is used or not, be aware that the fiber control board cannot control the laser; if the control board is confirmed to be correct, please check whether the "PWM+ signal" and "On/Off optical signal" are connected correctly or not. Use a multimeter to check: switch the multimeter to the DC voltage, set the power to "50" on the marking software, and then perform continuous marking. At this time, the PWM+ signal should have a voltage output of about 2.5V, and the "On/Off optical signal" voltage should be 5V, and then set the power further to "90" to continuously mark. At this time, the PWM+ signal should have a voltage output of about 4.2V, and the "On/Off optical signal" voltage should be still 5V, which means the signal is normal. If an oscilloscope is available, it is more accurate to use an oscilloscope to do the check.
 - Check whether the terminals of the signal cable are soldered correctly or not. The 4-pin of the laser to be connected to the GND of the control board; the 5-pin to connected to the PWM+ signal of the control board, and the 7-pin connected to the On/Off optical signal of the control board.
 - Check whether the plug of signal cable is firm or not.

5.2 The laser intensity becomes weak after working for a period of time?

- Whether the chiller is on or not.
- Whether the working temperature is normal or not.
- Whether the water level of the chiller is too low or not.
- Whether the field lens and galvanometer are polluted or not.

6. After sale service

6.1 Warranty

All laser source products from Tianjin Maiman Laser Technology Co., Ltd. come with an 18-month warranty period, which certifies that your laser is found to be free of any defects in material or workmanship. This warranty applies regardless of your laser application. It does not cover any issues that may arise due to operator negligence, environmental factors, accident, alterations, or improper maintenance. Tianjin Maiman Laser Technology Co., Ltd maintains the sole authority to make any claims or statements regarding warranty on its products. Maiman Laser reserves the right to make changes or improvements to product design without notice, and without expectation of equivalent changes in products previously manufactured or shipped.

6.2 Returns

If a failure should occur, please contact maimanlaser@maimanlaser.com or +86 17526524352. If a laser or accessories needs to be returned, a Return Merchandise Authorization(RMA) will be issued. Any laser returned without an RMA will be at your sole expense.

Typically, for failure within the 18 months, the client shall be responsible for shipping costs to Tianjin Maiman Laser Technology Co., Ltd. or its distributors. Maiman Laser or its distributors will pay all shipping costs to return the item(s) to the client.

When requesting an RMA please have the following information ready:

Date of purchase:

Date of receiving the laser:

Laser Model:

Date the issue was first discovered:

Brief description of the issue:

Find out the RMA as completely as possible. For any returns, please ship the item(s) to:

Tianjin Maiman Laser Technology Co., Ltd.

Attn: Overseas Department, Lynn Zhang

201, D6-A, East Huigu Industrial Park, Xiqing District, Tianjin, China

Include the laser and all accessories when returning the laser. This allows Maiman Laser to determine the source of the issue.

Tianjin Maiman Laser Technology Co., Ltd.

Address: 201, D6-A, East Huigu Industrial Park, Xiqing District, Tianjin

Tel: +86-22-8789 4207 8789 4217

Mobile: +86-22 175 2652 4352

Fax: +86-228789 4217

Web: www.maimanlaser.com

E-mail: maimanlaser@maimanlaser.com



[View website](#)



[View catalog](#)



WhatsApp

Tianjin Maimanlaser Technology Co., Ltd. reserves the copy right of this catlog and reserves all the rights to change the information and specifications contained in this catlog without prior notice.

Version updated on April 29th, 2024.